

Mergers

Jurisdictional and procedural guidance



Preface

This guidance forms part of the advice and information published by the Office of Fair Trading (the OFT) under section 106 of the Enterprise Act 2002 (the Act). This guidance is designed to provide general information and advice to companies and their advisers on the procedures used by the OFT in operating the merger control regime set out in the Act. It also includes guidance on when the OFT will have jurisdiction to review mergers under the Act.

This guidance should be read alongside the OFT publications *Mergers – substantive assessment guidance* (OFT516), *Guidance note revising ‘Mergers – substantive assessment guidance’* (OFT516a)¹ and *Revision to Mergers – substantive assessment guidance – Exception to the duty to refer: markets of insufficient importance* (OFT516b).²

More specifically, this guidance provides extensive details of the OFT’s merger review procedures. It is primarily concerned with those mergers in the United Kingdom (UK) that are covered by the provisions of the Act. However, it also briefly looks at those mergers that fall to the European Commission (the Commission) under the European Community Merger Regulation (the EC Merger Regulation³), and the relationship between domestic and European merger control systems. It explains the roles of the OFT, the Department for Business, Innovation and Skills (BIS), and the Competition Commission (the CC).

This new guidance supersedes previously published information on the OFT’s merger review process and jurisdictional questions, including the OFT publications: *Mergers – procedural guidance* (OFT526), *Mergers – guidance note on the calculation of turnover for the purposes of Part 3 of The Enterprise Act 2002* (July 2003), *Interim arrangements for informal advice and pre-notification contacts* (April 2006) and *Explanatory note in relation to ‘Interim arrangements for informal advice and pre-notification contacts’* (October 2007). It also supersedes chapter 2 of the OFT publication *Mergers – substantive assessment guidance* (OFT516), although the remainder of that guidance is unaffected by this guidance.⁴

This guidance sets out the OFT’s current practice (and intended future practice) as from the date of publication. This guidance reflects the views of the OFT at the time of publication and may be revised from time to time to reflect changes in best practice, legislation and the results of experience, legal

1 These publications are expected to be superseded by the forthcoming UK Merger Assessment Guidelines, published jointly with the Competition Commission.

2 The OFT intends to publish separate guidance on its exceptions to the duty to refer and undertakings in lieu.

3 Council Regulation (EC) No. 139/2004 of 20 January 2004 on the control of concentrations between undertakings, OJ 2004 L24/1.

4 This publication is expected to be superseded by the forthcoming UK Merger Assessment Guidelines, published jointly with the CC.

judgments and research. This guidance may in due course be supplemented, revised or replaced. The OFT's web site will always display the latest version of the guidance. Where there is any difference in emphasis or detail between this guidance and other guidance produced by the OFT, the most recently published guidance takes precedence.

Although it covers most of the points likely to be of immediate concern to businesses and their advisers, this guidance makes no claim to be comprehensive. It cannot, therefore, be seen as a substitute for the Act and the regulations and orders made under the Act, or the Competition Act 1998, or for the EC Merger Regulation and other regulations and guidance issued by the Commission, nor can it be cited as a definitive interpretation of the law. Anyone in any doubt about whether they may be affected by the legislation should consider seeking legal advice.

Furthermore, although the OFT will have regard to this guidance in handling mergers under the Act, the OFT will apply this guidance flexibly and may depart from the approach described in the guidance where there is an appropriate and reasonable justification for doing so.

Contents

Chapter		Page
1	Introduction	4
2	The legal framework	8
3	What is a relevant merger situation?	11
4	Notifying mergers to the OFT	30
5	Contents of submissions	53
6	The assessment process	60
7	Fees	79
8	Remedies	82
9	Public interest mergers	95
10	Interaction with other processes	102
11	The EC Merger Regulation	104
Annexes		
A	The Statutory Merger Notice	120
B	Guidance on the calculation of turnover for the purposes of Part 3 of the Enterprise Act 2002	124
	Contact addresses	130

1 Introduction

Scope of the guidance

- 1.1 This guidance discusses in detail the criteria that the OFT applies to determine whether it has jurisdiction under the Act (chapter 3) and the policies and procedures that the OFT will use in discharging its functions under the Act (chapters 4 to 11).
- 1.2 This guidance does not address in detail the substantive ‘substantial lessening of competition’ test against which the OFT assesses mergers. Detailed information on the substantive test for mergers, and how the OFT carries out its substantive assessment, is provided in the OFT publications *Mergers – substantive assessment guidance* (OFT516) and *Guidance note revising ‘Mergers – substantive assessment guidance’* (OFT516a)⁵ and *Revision to Mergers – substantive assessment guidance – Exception to the duty to refer: markets of insufficient importance* (OFT516b).⁶

5 These publications are expected to be superseded by the forthcoming UK Merger Assessment Guidelines, published jointly with the CC.

6 The OFT intends to publish separate guidance on its exceptions to the duty to refer and undertakings in lieu.

Who does what?

- 1.3 The Act assigns distinct roles to the OFT, the CC and the Secretary of State. How these roles interrelate is summarised in the following paragraphs. Background information on the interrelationship with the Commission is also provided.

The Office of Fair Trading

- 1.4 The OFT was re-established as a corporate body by the Act on 1 April 2003 to carry out certain functions on behalf of the Crown.
- 1.5 Under the Act, the OFT has a function to obtain and review information relating to merger situations, and a duty to refer to the CC for further investigation any relevant merger situation where it believes that it is or may be the case that the merger has resulted or may be expected to result in a substantial lessening of competition in a UK market. The OFT must bring to the attention of the Secretary of State any merger it is investigating which it believes raises a material public interest consideration. The OFT must advise the Secretary of State on any mergers which might fall within the scope of the public interest or the

special public interest provisions of the Act where the Secretary of State has served an intervention notice in that case (see chapter 9).

- 1.6** If a merger reference is made to the CC, the OFT has a duty to provide to the CC any information in its possession that the CC may reasonably require to enable it to carry out its functions.
- 1.7** In anticipated or completed mergers, the OFT can, either on its own account, or, in public interest cases where so requested by the Secretary of State, negotiate undertakings in lieu of a reference to the CC (see chapter 8).
- 1.8** If asked to do so, the OFT may also (in appropriate cases, where certain conditions are met) provide informal advice to the parties involved in contemplated mergers (see chapter 4).
- 1.9** The OFT employs administrative, legal, economics and accounting staff to perform these functions and duties. The activities of the OFT in relation to mergers are coordinated by its Mergers Group (the Group), part of the Markets and Projects Division.
- 1.10** The OFT may also contact other governmental departments, sectoral regulators, industry associations and consumer bodies for their views on merger cases where appropriate. Sectoral regulators may carry out their own public consultation before providing comments to the OFT.

The Competition Commission

- 1.11** The CC is an independent non-governmental body consisting of members and a staff secretariat with expertise in competition matters.
- 1.12** The CC investigates mergers referred to it by the OFT (and occasionally by the Secretary of State) to determine whether there is a merger situation that qualifies for investigation and, if so, whether that merger situation has resulted, or may be expected to result, in a substantial lessening of competition.
- 1.13** The CC determines the outcome of merger cases referred to it by the OFT, and reports to the Secretary of State on those mergers referred

to it by the Secretary of State under the public interest regime. It has no authority to investigate any merger unless it has been asked to do so by the OFT or the Secretary of State under the relevant statutory power.

The Secretary of State

- 1.14** The Secretary of State heads BIS and has a role in certain public interest cases (see chapter 9). The Secretary of State is able to modify certain provisions of the Act, for example, those relating to jurisdictional thresholds and, through secondary legislation, the level of merger fees.
- 1.15** The Act also provides scope for the Secretary of State to intervene in mergers that do not qualify under the normal jurisdictional tests. At the time of writing, these merger situations comprise instances where one of the enterprises concerned is a relevant government contractor (as defined) in defence mergers, or where the merger involves certain newspaper or broadcasting companies. These are known as special merger situations and are considered under the special public interest regime of the Act.

The European Commission

- 1.16** Under the EC Merger Regulation, the Commission has jurisdiction over those mergers that have a 'Community dimension' (calculated by reference to the turnover of the merging undertakings). These proposed mergers have to be notified to the Commission. In addition, the Commission may, if the parties' request prior to notification, obtain jurisdiction to review mergers that do not have a Community dimension but that are capable of being reviewed in three or more Member States. Also, the Commission may obtain jurisdiction where one or more Member States requests that the Commission examine a transaction that does not have a Community dimension. In any of these three situations, whenever the Commission has jurisdiction, national merger law does not – with very limited exceptions (see chapter 11) – apply to the merger.

- 1.17** Where a transaction does have a Community dimension, and is therefore notifiable to the Commission, but has its principal competitive effect in the UK, it may be referred back, in whole or in part, for investigation by the OFT. This may occur through a pre-notification request by the parties or by the OFT itself seeking a reference back after the merger has been notified to the Commission.
- 1.18** As a result of this flexibility in the allocation of jurisdiction between the Commission and the OFT, the OFT would encourage companies to keep it informed of an intention to notify a merger to the Commission where there are potential competition concerns that may arise in the UK.
- 1.19** The UK government may take certain steps in respect of mergers notified under the EC Merger Regulation to the Commission that affect national security, and other legitimate non-competition interests, including asking the OFT to advise under the Act on any action needed to protect such legitimate interests in mergers that are otherwise being examined by the Commission.

Further information

- 1.20** Further information can be obtained from:

The Mergers Group
Office of Fair Trading
Fleetbank House
2-6 Salisbury Square
London EC4Y 8JX

Tel: 020 7211 8917/8452/8586, Fax: 020 7211 8916

and from the OFT's website: www.oft.gov.uk

2 The legal framework

2.1 The Act imposes a duty on the OFT to refer completed and anticipated mergers to the CC for further investigation if it believes that it is or may be the case that:

- a relevant merger situation has been created or arrangements are in progress or in contemplation which, if carried into effect, will result in the creation of a relevant merger situation, and
- the creation of that situation has resulted, or may be expected to result, in a substantial lessening of competition within any market or markets for goods or services in the UK.⁷

2.2 The OFT may, however, decide not to make a reference if it believes that:

- the market concerned is not, or the markets concerned are not, of sufficient importance to justify the making of a reference to the CC
- any relevant customer benefits in relation to the creation of the relevant merger situation outweigh the substantial lessening of competition concerned and any adverse effects of the substantial lessening of competition concerned, or
- in the case of an anticipated merger, the arrangements concerned are not sufficiently far advanced, or are not sufficiently likely to proceed, to justify the making of a reference to the CC.

2.3 Under section 22(3)(c) of the Act, the OFT cannot refer a completed merger if the relevant merger situation concerned is being, or has been, dealt with in connection with the reference made of the anticipated merger.

2.4 Where the OFT finds that it is under a duty to refer a merger to the CC, it may under section 73 of the Act accept undertakings in lieu of a reference to remedy, mitigate or prevent the substantial lessening of competition concerned or any adverse effect of the merger (see chapter 8).

2.5 Following a reference to it, the CC must decide whether a relevant merger situation has been created and, if so, whether the creation of that situation has resulted, or may be expected to result, in a

⁷ Crown dependencies are not part of the United Kingdom and may or may not have merger control laws applicable in their respective jurisdictions (for example Jersey has a specific merger control regime: see the Jersey Competition Regulatory Authority at www.jcra.je).

substantial lessening of competition within any market or markets in the UK for goods or services. If the CC finds that there is an anti-competitive outcome it shall decide:

- whether action should be taken by it, or by others, to remedy, mitigate or prevent the substantial lessening of competition concerned or any adverse effect that has resulted from, or may be expected to result from, the substantial lessening of competition, and
- if action is to be taken, what action should be taken and what is to be remedied, mitigated or prevented.

2.6 While most mergers that take place in the UK will raise no issues relating to a substantial lessening of competition, the merger control process is designed to allow the OFT to identify those where such issues may arise, so that they may be examined in greater detail through a reference to the CC or so that appropriate remedies may be offered.

2.7 The substantial lessening of competition test found in the Act will be met if the OFT has a reasonable belief, objectively justified by relevant facts, that there is a realistic prospect that the merger will lessen competition substantially. Further guidance on the application of this test may be found in the OFT publications *Mergers – substantive assessment guidance* (OFT516) and *Guidance note revising ‘Mergers – substantive assessment guidance’* (OFT516a),⁸ and in the OFT’s published decisions on its website: www.of.gov.uk

2.8 The Act also permits intervention by the Secretary of State in public interest cases. In these cases, the Secretary of State may take public interest factors other than the OFT’s competition assessment into account in deciding whether to clear, refer or remedy a merger. The public interest considerations that the Secretary of State may take into account are set out in section 58 of the Act. National and public security considerations were originally specified in the Act as public interest considerations. The Communications Act 2003 introduced new public interest considerations relating to newspaper and other media mergers. In October 2008, the Secretary of State added by Order the maintenance of the stability of the UK financial system as a new public interest consideration in the Act. The Secretary of State retains

⁸ These publications are expected to be superseded by the forthcoming UK Merger Assessment Guidelines, published jointly with the CC.

the power to add further public interest considerations by statutory instrument.

- 2.9** The Secretary of State is also able to intervene in special public interest cases where the standard jurisdictional thresholds relating to share of supply and turnover are not satisfied. There will be no competition assessment in such cases.

3 What is a relevant merger situation?

- 3.1** The Act's definition of a 'relevant merger situation' covers several different kinds of transaction and arrangement.⁹ A company that buys or intends to buy a majority shareholding or a significant minority shareholding in another company is the most obvious example, but the transfer or pooling of assets or the creation of a joint venture may also give rise to merger situations. The Act's provisions apply both to mergers that have already taken place (subject to time limits) and to those that are proposed or in contemplation.
- 3.2** As a general rule, mergers that fall under the scope of the EC Merger Regulation are excluded from review under the Act. Further information on the interaction of EC merger control laws and the Act is provided in chapter 11.

⁹ Whilst this guidance covers a number of detailed jurisdictional questions on which stakeholders have in the OFT's experience sought details and information, it does not follow that the OFT expects such factual scenarios to arise routinely.

Introduction

- 3.3** A merger must meet all three of the following criteria to constitute a relevant merger situation for the purposes of the Act:
- two or more enterprises (broadly speaking, business activities of any kind – see section 129 of the Act) must cease to be distinct, or there must be arrangements in progress or in contemplation which, if carried into effect, will lead to enterprises ceasing to be distinct
 - either:
 - the UK turnover associated with the enterprise which is being acquired exceeds £70 million (known as 'the turnover test'), or
 - the enterprises which cease to be distinct supply or acquire goods or services of any description and, after the merger, together supply or acquire at least 25 per cent of all those particular goods or services of that kind supplied in the UK or in a substantial part of it. To qualify, the merger must result in an increment to the share of supply or consumption and the resulting share must be at least 25 per cent. In practice therefore, the share of supply test can only be met where the enterprises concerned supply or acquire goods or services of a similar kind (this test is hereafter referred to as 'the share of supply test'), and

- either the merger must not yet have taken place, or must have taken place not more than four months before the reference is made, unless the merger took place without having been made public and without the OFT being informed of it (in which case the four month period starts from the earlier of the time the merger was made public or the time the OFT was told about it).

3.4 It is implicit in these criteria that at least one of the enterprises must be active within the UK. Where the turnover test is met, this will by definition be because the target generates turnover in the UK. For the share of supply test, each of the enterprises ceasing to be distinct that are being included for the purposes of share of supply must be active in supplying or acquiring goods or services within the UK or a substantial part of the UK. These principles apply equally to non-UK companies that sell to (or acquire from) UK customers or suppliers. In assessing whether a firm is active in the UK, the OFT will have regard to whether its sales are made directly or indirectly (via agents or traders) to UK customers.

3.5 In making a reference to the CC, the OFT (or the Secretary of State in public interest cases) need only have a reasonable belief that it is or may be the case that a relevant merger situation has been created or that arrangements are in progress or in contemplation which, if carried into effect, will result in the creation of a relevant merger situation. The OFT interprets this provision to mean that a reference is possible if, on the basis of the evidence available to it, there is at least a realistic prospect that a relevant merger situation exists or will exist. The statutory context of the Act means that, in those cases where there is genuine uncertainty on the existence of a relevant merger situation, this question is one for resolution by the CC on the basis of a detailed investigation where the duty to refer would otherwise be met.

3.6 In the context of mergers that have not yet completed, the OFT will generally consider that ‘arrangements are in progress or in contemplation’ for the purposes of section 33 of the Act where a public announcement has been made by the parties concerned.¹⁰

¹⁰ In the case of a public bid, this will generally mean announcement of a possible offer or of a firm intention to make an offer.

Enterprises ceasing to be distinct

- 3.7** Two enterprises will 'cease to be distinct' if they are brought under common ownership or control.¹¹

Enterprises

- 3.8** The term 'enterprise' is defined in section 129 of the Act as the activities, or part of the activities, of a business. This does not mean that the enterprise in question need be a separate legal entity: it simply means that the activities in question should be carried on for gain or reward. However, there is no requirement that the transferred activities generate a profit or dividend for shareholders: indeed, the transferred activities may be loss making or conducted on a not-for-profit basis.¹²
- 3.9** In making a judgement as to whether or not the activities of a business, or part of a business, constitute an enterprise under the Act, the OFT will have regard to the substance of the arrangement under consideration, rather than merely its legal form.¹³ As a result, it may not be the case that one single factor will prove determinative in reaching a conclusion. Rather, the OFT will make an assessment based on the totality of all relevant considerations.
- 3.10** An 'enterprise' may comprise any number of components, most commonly including the employees working in the business and the assets and records needed to carry on the business, together with the benefit of existing contracts and/or goodwill. In some cases, the transfer of physical assets alone may be sufficient to constitute an enterprise: for example, where the facilities or site transferred enables a particular business activity to be continued. Intangible assets such as intellectual property rights are unlikely, on their own, to constitute an 'enterprise' unless it is possible to identify turnover directly related to the transferred intangible assets that will also transfer to the buyer. In interpreting these principles, the OFT will have regard to the following specific considerations.
- The transfer of 'customer records' is likely to be important in assessing whether an enterprise has been transferred.

¹¹ A joint venture may qualify as a relevant merger situation in the UK in circumstances where it does not qualify as a concentration under the EC Merger Regulation given the wide definition of an enterprise in section 129 of the Act compared to that of a full function joint venture in Article 3 of the EC Merger Regulation. In the case of a 'start-up' joint venture, the question under the Act will be whether the activities transferred to the joint venture by one or more parents (or acquired from a third party) are sufficient to constitute an enterprise.

¹² See for example the Completed merger between the Imperial Cancer Research Fund and the Cancer Research Campaign, Report of 25 March 2002 (although decided under the Fair Trading Act 1973, the result would not differ under the Act).

¹³ For example, the fact that there was no direct sale agreement between the existing cinema operator and the new cinema operator did not mean that enterprises did not cease to be distinct for the purposes of the Act in the Anticipated acquisition by CineWorld Group plc, through its subsidiary Cine-UK Limited, of the Cinema Business operating at the Hollywood Green Leisure Park, Wood Green 17 March 2008.

14 The Transfer of Undertakings (Protection of Employment) Regulations 2006.

- The application of the TUPE regulations¹⁴ would be regarded as a strong factor in favour of a finding that the business transferred constitutes an enterprise.
- The OFT would normally (although not inevitably) expect a transfer of an enterprise to be accompanied by some payment for the goodwill obtained by the purchaser. The presence of a price premium being paid over the value of the land and assets being transferred would be indicative of goodwill being transferred.

3.11 The OFT will apply the same principles in situations where the business being acquired is not trading at the time of the merger. The fact that the business is no longer actively trading does not in itself prevent the business acquired from being an enterprise for the purposes of the Act. In addition to the factors generally applicable, in such a situation the OFT will consider:

- the period of time elapsed since the business was last trading
- the extent and cost of the actions that would be required in order to reactivate the business as a trading entity
- the extent to which customers would regard the acquiring business as, in substance, continuing from the acquired business, and
- whether, despite the fact that the business is not trading, goodwill or other benefits beyond the physical assets and/or site themselves could be said to be attached to the business and part of the sale.

3.12 None of these factors, individually, is likely to be conclusive. The OFT will assess all of the above factors, and any other relevant circumstances (including whether there is evidence that the closure of the business was designed to avoid merger control), in the round, with a view to determining whether the business in question should be considered as an enterprise given the structure and purposes of the Act.

3.13 Outsourcing arrangements involving ongoing supply arrangements will not generally result in enterprises ceasing to be distinct, but may do so where they involve the permanent (or long-term) transfer of assets, rights and/or employees to the outsourcing service supplier and where those may be used to supply services other than to the original owner/

employer. The OFT will assess whether, overall, the assets, rights and employees transferred to the outsourcing service supplier are such as to constitute an enterprise under the principles set out above.¹⁵

Control

3.14 'Ceasing to be distinct' is defined in section 26 of the Act as two enterprises being brought under common ownership or control. 'Control' is not limited to the acquisition of outright voting control but includes situations falling short of outright voting control. Section 26 of the Act distinguishes three levels of interest referred to as 'control' (in ascending order):

- Company A, the acquirer, may acquire the ability materially to influence the policy of Company B, the target, (known as 'material influence')
- Company A may acquire the ability to control the policy of Company B (known as 'de facto' control), and
- Company A may acquire a controlling interest in Company B (known as 'de jure', or 'legal' control).

Material influence

3.15 The ability to exercise material influence is the lowest level of control that may give rise to a relevant merger situation,¹⁶ although the OFT has to date encountered this level of control more frequently than 'de facto' control (discussed in paragraph 3.29 below). In assessing material influence in the context of the Act, the OFT focuses on the acquirer's ability materially to influence policy relevant to the behaviour of the target entity in the marketplace. The policy of the target in this context means the management of its business, in particular in relation to its competitive conduct, and thus includes the strategic direction of a company and its ability to define and achieve its commercial objectives.

3.16 Section 26(3) of the Act provides that the OFT may treat material influence (and indeed 'de facto' control) as equivalent to control. The OFT's practice is to treat material influence as control whenever it considers that the test for reference would be met in the case in question.

¹⁵ See Anticipated contract award to Nuclear Management Partners Limited as the Parent Body Organisation for Sellafield Limited 22 October 2008 (for analogous analysis).

¹⁶ The ability materially to influence the policy of the target (under the Act) is a lower standard than the ability to exercise decisive influence (the standard used to define control under Article 3 of the EC Merger Regulation).

3.17 Assessment of material influence requires a case by case analysis of the overall relationship between the acquirer and the target. In making this assessment, the OFT will have regard to all the circumstances of the case. In most cases, a finding of material influence will be based on the acquirer's ability to influence the target's policy through exercising votes at shareholders' meetings, together with any additional supporting factors (as discussed in paragraph 3.27 below) that might suggest that the acquiring party exercises an influence disproportionate to its shareholding. However, material influence may also arise as a result of the ability to influence the board of the target and/or through other arrangements. Each of these sources of influence (shareholding, board representation and other sources) are covered below.

3.18 The variety of commercial arrangements entered into by firms makes it difficult to state categorically what will (or will not) constitute material influence. However, the following matters are of particular relevance, although this list is by no means exhaustive.

Shareholdings

3.19 A shareholding conferring on the holder more than 25 per cent of the voting rights in a company generally enables the holder to block special resolutions; consequently, a share of voting rights of over 25 per cent is likely to be seen as presumptively conferring the ability materially to influence policy – even when all the remaining shares are held by only one person.

3.20 Although no such presumption applies below 25 per cent, the OFT may examine any case where there is a shareholding of 15 per cent or more in order to see whether the holder might be able materially to influence the company's policy. Exceptionally, a shareholding of less than 15 per cent might attract scrutiny where other factors indicating the ability to exercise material influence over policy are present. In practice, the OFT is likely to investigate such low levels of shareholding only where they concern one business taking a stake in a direct competitor.

3.21 In considering whether material influence may be present in a particular case, the key question for the OFT is not whether the acquiring party has the right to block special resolutions, but whether, given other

factors, it is able to do so as a practical matter.¹⁷ This gives effect to the general principle that the purpose of UK merger control is to enable the authorities to consider the commercial realities and results of transactions and that the focus should be on substance and not legal form. As such, other factors relevant to an assessment of a particular shareholding may include:

- the distribution and holders of the remaining shares, in particular whether the acquiring entity's shareholding makes it the largest shareholder
- patterns of attendance and voting at recent shareholders' meetings based on recent shareholder returns,¹⁸ and, in particular, whether voter attendance is such that a shareholder holding 25 per cent of the voting rights or less would be able in practice to block special resolutions¹⁹
- the existence of any special voting or veto rights attached to the shareholding under consideration, and
- any other special provisions in the constitution of the company conferring an ability materially to influence policy.

3.22 Finally, an acquirer's shareholding, whilst insufficient in itself to enable the acquirer to defeat a special resolution, may still in exceptional cases be sufficient to enable it materially to influence a policy that would require a special resolution. In this respect, the OFT will have regard to the status and expertise of the acquirer, and its corresponding influence with other shareholders, and will consider whether, given the identity and corporate policy of the target company, the acquirer may be able materially to influence policy formulation at an earlier stage through, for example, meetings with other shareholders. Where the very fact that a company's appetite for pursuing certain strategies at all would be reduced if it were aware that these strategies would be likely to cause conflict with the acquirer, this may be a relevant factor in determining material influence.

Board representation

3.23 In addition to the ability materially to influence policy through the voting of shares, the OFT's determination may also, or alternatively,

17 See Acquisition by British Sky Broadcasting Group plc of a 17.9 per cent stake in ITV plc, Report to the Secretary of State for Trade and Industry 27 April 2007 and British Sky Broadcasting Group plc v the CC and the Secretary of State [2008] CAT 25.

18 Given that any prediction of attendance and voting at shareholders' meetings is complex, involving a wide range of factors, the OFT considers that, all other things being equal, and in the context of a first phase investigation, patterns of participation at recent shareholders' meetings of a particular company (for example over the last three years) are likely to be the best available indication of future participation.

19 A shareholding of 25 per cent or less may be seen as likely to give rise to a finding of material influence where patterns of attendance and voting at recent shareholders' meetings indicate that the relevant shareholder is likely to have the ability to block special resolutions. In making this determination, the OFT may have regard to the votes of other shareholders that it considers may be expected to be voted with the acquirer against a special resolution.

turn on whether the acquirer is able materially to influence the policy of the target entity through board representation. Indeed, it is possible that board representation alone may, in certain circumstances, confer material influence.

- 3.24** Whilst the vast majority of board appointments, in particular non-executive appointments, will not raise substantive concerns of the type targeted by the Act, the OFT would be concerned to investigate under the Act cross-directorships between competing businesses where such representation raised the possibility that one party could in fact have material influence over a competitor and thereby raise the prospect that the duty to refer could be met.
- 3.25** Whether as a free-standing basis for material influence or as a supporting factor in the context of a shareholding, in this connection, the OFT will review the proportion of board directors appointed by the ‘acquiring’ entity and the corporate/industry expertise of members of the board appointed by the ‘acquirer’. This in turn requires assessment of the identities, relative experience and incentives of other board members.²⁰
- 3.26** Where the level of shareholding held by the acquiring party gives it a right to obtain board representation, and the OFT considers that the prospect of those rights being taken up in the future is more than fanciful, the OFT considers it appropriate to have regard to this possibility in relation to its jurisdictional assessment (and potentially also in its substantive assessment).

Other sources of material influence

- 3.27** The OFT may also consider whether any other factors, such as agreements with the company, enable the acquirer materially to influence policy. These might include the provision of consultancy services to the target or might, in certain circumstances, include agreements between firms that one will cease production and source all its requirements from the other.
- 3.28** Financial arrangements may in certain circumstances confer material influence where the conditions are such that one party becomes so

²⁰ See MMC Report – British Airways Plc and Sabena SA: A report on the merger situation Cm 1155 July 1990.

dependent on the other that the latter gains material influence over the company's commercial policy (for example, where a lender could threaten to withdraw loan facilities if a particular policy is not pursued, or where the loan conditions confer on the lender an ability to exercise rights over and above those necessary to protect its investment, say, by options to take control of the company or veto rights over certain strategic decisions).²¹

De facto control

- 3.29** The OFT considers that 'de facto' control may, in broad terms, be regarded as similar in nature to the concept of 'decisive influence' under the EC Merger Regulation.
- 3.30** The OFT is likely to reach a belief that merger arrangements give rise to a position of 'de facto' control when an entity is clearly the controller of a company, notwithstanding that it holds less than the majority of voting rights in the target company (ie it does not have a controlling interest). This is likely to include situations where the acquirer has in practice control over more than half of the votes actually cast at a shareholder meeting. It might also involve situations where an investor's industry expertise leads to its advice being followed in nearly all cases (although this factor could equally be relevant to a finding of material influence).
- 3.31** The OFT has the ability under section 26(3) of the Act to decide whether or not to treat 'de facto' control as a controlling interest for the purposes of the Act; but, as explained in the context of material influence (see paragraph 3.16 above), its practice is to do so whenever it considers that the test for reference would be met in the case in question.

A controlling interest

- 3.32** A 'controlling interest' generally means a shareholding giving more than 50 per cent of the voting rights in a company. Only one shareholder can have a controlling interest, but it is not uncommon for a company to be subject to the control (in the wider senses described above) of two or more major shareholders at the same time – in a joint venture, for instance. Therefore, a significant minority shareholder may be seen as being able materially to influence a company's policy even though someone else owns a controlling interest.

²¹ See MMC Report - Stora Kopparbergs Bergslags AB/Swedish Match NV, and Stora Kopparbergs Bergslags AB/The Gillette Company: A report on the merger situations Cm 1473 March 1991.

Acquiring control by stages

- 3.33** Under section 26(4) of the Act, should a shareholding (and/or a level of board representation) that confers the ability materially to influence a company’s policy increase subsequently to a level that amounts to ‘de facto’ control or a controlling interest, that further acquisition will produce a new relevant merger situation (which is therefore potentially liable to reference to the CC).²² The same applies to a move from ‘de facto’ control to a controlling interest.
- 3.34** In principle, therefore, if Company A acquires Company B in stages, this could give rise to three separate relevant merger situations:²³ first, as Company A acquires material influence; then to ‘de facto’ control; and, finally, to a controlling interest. But further acquisitions of a company’s shares by a person who already owns a controlling interest do not give rise to a new merger situation.
- 3.35** For the purposes of a merger reference, where a person acquires control of an enterprise (in any of the three senses described above) during a series of transactions within a single two year period, section 29 of the Act allows them to be treated as having occurred or occurring simultaneously on the date of the last transaction. In giving effect to this provision, the OFT may take into account transactions in contemplation (that is where the last of the events within the two year period has not yet occurred).²⁴
- 3.36** A new merger situation would not arise directly from the fact that there has been a reduction in the level of a shareholder’s control (for example from a controlling interest to ‘de facto’ control). However, it is possible in these circumstances that a merger situation could arise through a third party thereby acquiring material influence, ‘de facto’ control or a controlling interest.

Temporary merger situations

- 3.37** The Act does not define the period of time that a merger situation should last in order for it to qualify as a relevant merger situation under the Act. In theory, therefore, acquisitions of control intended purely as a temporary step in a wider overall transaction might constitute a

²² See for example Anticipated acquisition by Air Products Group Limited of a controlling interest in CryoService Limited 16 June 2008. Such cases may qualify on the share of supply test (as well as the turnover test) given that section 26(4) of the Act allows for the acquirer to be ‘treated’ as bringing the target under its control (notwithstanding that it already had material influence or ‘de facto’ control over the target) such that there would therefore (under such ‘treatment’) be an increment in the share of supply.

²³ Clearly, it does not follow that the OFT would find that moving from one level to another would itself create the realistic prospect of a substantial lessening of competition.

²⁴ Article 3 Enterprise Act 2002 (Anticipated Mergers) Order 2003 SI 2003/1595.

relevant merger situation. In practice, the most common form of such an arrangement is a break-up bid.²⁵

- 3.38** Break-up bids occur where one or more entities purchase an enterprise pursuant to an agreement that the acquired enterprise will be divided up according to a pre-existing plan upon completion of the transaction. In some cases, the break-up bid is structured in anticipation of merger control concerns that would otherwise occur. The question therefore arises whether the OFT will consider the first transaction as a separate relevant merger situation concerning the entire target enterprise, or whether it will examine the ultimate acquisitions in the second step (that is after the target enterprise is split up).²⁶
- 3.39** Unlike under the EC Merger Regulation, the nature of the voluntary regime under the Act means there is, as a starting point, no requirement on the party or parties acquiring control under the first step in the above scenario to notify the OFT about the first acquisition.
- 3.40** In terms of whether the OFT will investigate the initial acquisition on its own initiative, the OFT will generally be unlikely to seek to examine a relevant merger situation where it is clear that it will be merely an interim step in the context of a wider transaction and that the subsequent steps will occur within the four month time period within which the OFT has the ability to refer the initial acquisition. Where the subsequent steps will not take place within four months of the completion of the initial acquisition, the OFT will not risk losing its ability to refer simply on the basis that it is intended that the current situation will not be permanent, as it can have no guarantee that this would be the case and would therefore risk breaching its duty to refer.
- 3.41** Where the initial acquisition is notified to it (whether the initial acquisition is anticipated or completed), the OFT would not be able to clear the transaction unconditionally simply on the basis that the situation as notified was not intended to be permanent. To avoid any referral to the CC that would otherwise be required on the basis of the initial acquisition, the OFT would require undertakings in lieu (potentially effectively codifying in undertakings the parties' intended break-up).²⁷

25 The other common situation involves stake-building in the context of a public bid. In this situation, the OFT's decision if and when to investigate on its own initiative a minority interest will depend on all the circumstances of the case (including the likelihood of a public bid being launched), and in particular its belief as to the extent of the competition concerns that could potentially result from a minority shareholding.

26 The OFT will apply similar principles to those set out below in the context of joint acquisitions for a start-up period.

27 By way of example, in GHG/Nuffield, GHG originally notified the completed acquisition of nine hospitals from Nuffield but, during the course of the OFT's investigation, completed the on-sale of the two hospitals that gave rise to local competition concerns. Given that the OFT's decision on whether or not to refer the merger is taken based on the facts existing at the time of the decision, rather than at the time of notification, the OFT was able to clear the retained acquisition of seven hospitals unconditionally because the on-sale transactions had completed by the time of the reference decision. Completed acquisition by General Healthcare Group of assets of Nuffield Hospitals 1 May 2008.

Associated persons

- 3.42** For purposes of considering whether an enterprise has ceased to be distinct, section 127 of the Act requires the OFT to consider whether a number of persons acquiring an enterprise are in fact ‘associated persons’ and thus should be viewed as acting together.
- 3.43** This situation will most commonly arise where the acquiring persons are related or have a signed agreement to act jointly to make an acquisition, although the Act does not require that each of the acquiring parties should themselves individually have control over the acquired entity for them all to be regarded as being associated persons. Separate groups of enterprises may be associated persons where a single member that is an associated person to each of those groups is common to both groups.

Time period for investigating mergers

- 3.44** For the OFT to be able to refer a merger to the CC either:
- the merger must not yet have taken place (that is must not have completed), or
 - under section 24 of the Act, the completed merger must have taken place not more than four months before the reference is made, unless the merger took place without having been made public and without the OFT being informed of it (in which case the four month period starts from the earlier of the time that material facts are made public or the time the OFT is told of material facts).
- 3.45** In cases where the OFT is not informed directly of material facts about the merger, the test under the Act for when the four month period commences is when material facts are ‘made public’, which is specified to be when they are ‘so publicised as to be generally known or readily ascertainable’. In interpreting these provisions of the Act, the OFT will have regard to the following factors.
- The OFT interprets ‘material facts’ to be the necessary facts that are relevant to the determination of the OFT’s jurisdiction in terms of the four month time period (but not in terms of other jurisdictional

issues). In practice, this means information on the identity of the parties and whether the transaction remains anticipated or has completed. The CC has previously considered that the fact that a merger has completed (that is, has fulfilled all conditions precedent) is a 'material fact' in this context.²⁸

- Where the parties do not notify the OFT, but 'make public' material facts about the transaction such that they are generally known or reasonably ascertainable, the OFT interprets this as meaning that such information could readily be ascertained by the OFT acting reasonably and diligently in accordance with its statutory functions. In practical terms, the OFT would consider that an acquiring party would normally be said to have 'made public' material facts where those facts had been publicised in the national or relevant trade press and where the acquiring party had itself taken steps to publicise the transaction at large, normally by publishing and prominently displaying on its own website a press release about the transaction.²⁹

3.46 When examining completed mergers, the OFT may under section 25 of the Act extend the four month time period if information requested by the OFT from the parties under section 31 of the Act is not supplied within the stated deadline.

3.47 Section 27(5) of the Act allows the OFT to treat successive events within a period of two years between the same parties (or in consequence of the same arrangements or transaction) as occurring simultaneously on the date of the latest event. The OFT has discretion in whether to apply this section; in exercising this discretion, the OFT will have regard to whether there is reason to believe that the relevant transactions were structured so as to avoid scrutiny under the merger control provisions of the Act.³⁰

The turnover test

3.48 The 'turnover test' is satisfied where the annual value of the UK turnover of the enterprise being acquired exceeds £70 million. In essence, the turnover in question is that achieved by the target, or targets, in the UK.³¹

28 See CC: Icopal Holding A/S and Icopal a/s: A report on the merger situation (2001), paragraph 2.50. That report concerned the application of the equivalent provisions of the Fair Trading Act 1973, but the result would not have differed under the Act.

29 See Completed acquisition by Genus plc of Local Breeders Limited 14 May 2008 and Completed acquisition by Tesco Stores Limited of Brian Ford's Discount Store Limited 22 December 2008.

30 See Completed acquisitions by Tesco plc of the Co-Operative Group's stores in Uxbridge Road, Slough 2 February 2004, in which the OFT declined to exercise its discretion.

31 See the Enterprise Act 2002 (Merger Fees and Determination of Turnover) Order 2003 SI 2003/1370.

3.49 Under section 28 of the Act, two types of situation may be distinguished for the purposes of calculating turnover: those where one or more enterprises remains under the same ownership and control after the merger, and those where no enterprise remains under the same ownership and control after the merger.

- Where one or more enterprises remains under the same ownership and control after the merger, turnover is calculated by taking the total value of all enterprises ceasing to be distinct (that is acquiring entities and target entities) and deducting the turnover of those enterprises that remain under the same ownership and control after the merger.
 - This situation includes a straightforward acquisition, in which the acquirer (A) and the target (T) cease to be distinct from each other. The turnover of the acquirer is deducted as it remains under the same ownership and control after the merger. Hence, the relevant turnover is that of the target. (See Figure 1 below.)
 - It also includes a situation where two or more companies (A and B) form a joint venture incorporating their assets and businesses in a particular area of activity. In this situation, each parent with control ceases to be distinct from the target business contributed to the joint venture by the other parent.³² As all the parent companies remain under the same ownership and control after the merger, and hence have their turnover deducted, the relevant turnover is the sum of the turnover of each of the contributed enterprises (which are, effectively, the target enterprises) (T_A and T_B).³³ (See Figure 2 below.)
- Where no enterprises remain under the same ownership and control after the merger, the relevant turnover is calculated by taking the total value of all enterprises ceasing to be distinct and deducting the turnover of the enterprise with the highest UK turnover.
 - This includes a situation in which two enterprises (A and B) come together to form a full legal merger.³⁴ The relevant turnover would be that of the existing enterprise with the smaller UK turnover (B). (See Figure 3 below.)

32 See CC: A report on the anticipated joint venture between BBC Worldwide Limited, Channel Four Television Corporation and ITV plc relating to the video on demand sector 4 February 2009, paragraph 3.53.

33 See Anticipated joint venture between Goodrich Corporation and Rolls-Royce plc 8 December 2008.

34 A full legal merger occurs where a full merger of A and B as equals is achieved by Newco C acquiring both. In this circumstance, neither A nor B survives the merger. Both firms are brought under common control, but neither remains under the same control as it was pre merger. The turnovers to be considered are those of A and B.

- It also includes a situation in which two or more companies (A, B and C) form a joint venture (Newco) incorporating all of their assets and businesses. The relevant turnover would be that of all the existing companies, excluding the company with the largest UK turnover. (See Figure 4 below.)

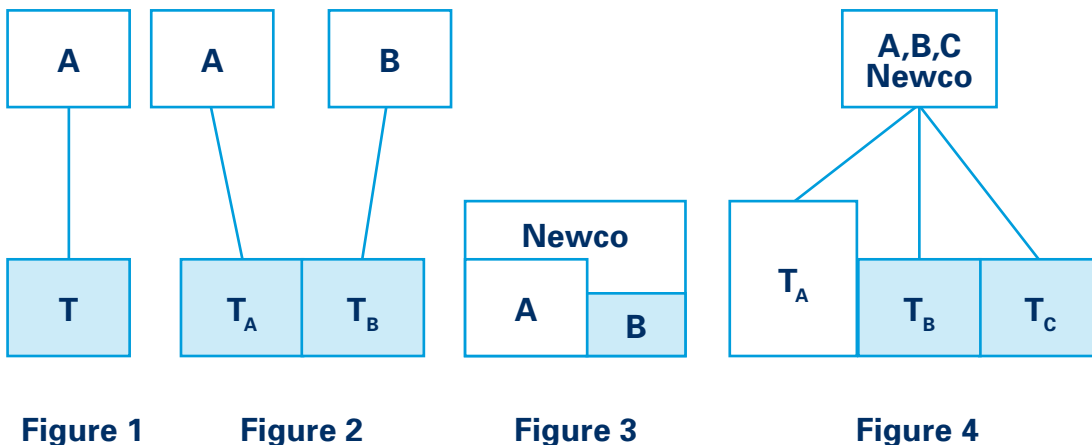

Shaded areas mark those businesses to be included in the turnover calculation

3.50 In principle, the turnover test applies to the turnover of the acquired enterprise that was generated in relation to customers within the UK³⁵ in the business year preceding the date of completion of the merger or, if the merger has not yet taken place, the date of the reference to the CC. The figures in the enterprise's latest published accounts will normally be sufficient to measure whether the turnover test is met, unless there have been significant changes since the accounts were prepared.³⁶ In this circumstance, more recent accounts would provide a better guide to the actual turnover of the enterprises concerned. Where company accounts do not provide a relevant figure, for example because only part of a business is being acquired, OFT will consider evidence presented by the parties and other interested parties to form its own view as to what it believes to be the value of UK turnover for jurisdictional purposes.

3.51 The basic principles set out above are elaborated further in Annexe B – Guidance on the calculation of turnover for the purposes of Part 3 of the Enterprise Act 2002.

³⁵ For the purpose of the geographic allocation of turnover, the OFT will generally follow the principles set out by the Commission in section C(V) (Geographic allocation of turnover) in its Consolidated Jurisdictional Notice under Council Regulation 139/2004 on the control of concentrations between undertakings OJ 2008 C95/1. Subject to the precisions outlined in the notice, the general rule is that turnover should be regarded as UK turnover for the purposes of the Act when the customer is located in the UK.

³⁶ In line with Article 11(3) of the Enterprise Act 2002 (Merger Fees and Determination of Turnover) Order 2003 SI 2003/1370, the OFT would regard acquisitions or divestments or other transactions or events as relevant for these purposes, but considers that the gain or loss of individual customers would, absent exceptional circumstances, be unlikely to be relevant.

The share of supply test

3.52 Under section 23 of the Act, the ‘share of supply test’ is satisfied only if the merged enterprises:

- both³⁷ either supply or acquire goods or services of a particular description, and
- will, after the merger,³⁸ supply or acquire 25 per cent or more of those goods or services, in the UK as a whole or in a substantial part of it.

3.53 Where an enterprise already supplies or acquires 25 per cent of particular goods or services, the test is satisfied so long as its share is increased as a result of the merger, regardless of the size of the increment.³⁹ Where there is no increment, the share of supply test is not met.

3.54 The increase in the share of supply must result from the enterprises ceasing to be distinct. In the case of an acquisition, this requires calculation of the share of supply based on the activities of the acquirer and the target company. In joint venture situations, the share of supply is calculated by reference to the activities of the joint venture, although it will include shares of the controlling joint venture parents where they remain active in the same activities as the joint venture. For example, where two companies, Company A and Company B, form a joint venture incorporating their assets and businesses in a particular area of activity, enterprises T_A and T_B respectively, the share of supply test is applied with reference to whether there is an increase in the share of supply between A, B, T_A and T_B in relation to the areas of activity in which T_A and/or T_B are active. The OFT would therefore not apply the share of supply test as between A and B outside the areas of activity of the joint venture.

3.55 The Act expressly provides the OFT with a wide discretion in describing the relevant goods or services, requiring only that, in relation to that description, the parties’ share of supply or acquisition is 25 per cent or more. In applying the share of supply test, the OFT will have regard to the following considerations.

- The share of supply test is not a market share test of the type used in the substantive assessment; therefore, the group of goods or

37 Where more than two enterprises cease to be distinct, at least two of them must supply or acquire such goods or services.

38 In accordance with section 23(9) of the Act, the OFT assesses whether the share of supply test is met at the time of its decision on reference. For this reason, anticipated future sales are not relevant to the assessment of jurisdiction.

39 In normal merger cases under the Act, there must be an increase in the share of supply in order for the OFT to have jurisdiction. However, no increase is required in relation to shares of supply of newspapers or broadcasting where the Secretary of State issues a special intervention notice (see paragraph 9.17 below).

services to which the jurisdictional test is applied need not amount to a relevant economic market, and can aggregate, for example, captive and merchant sales even if these might be treated differently in the substantive assessment.

- The OFT will have regard to any reasonable description of a set of goods or services to determine whether the share of supply test is met. This will often mean that the share of supply used corresponds with a standard recognised by the industry in question, although this need not necessarily be the case. In applying the share of supply test, the OFT may under section 23(5) of the Act have regard to the value, cost, price, quantity, capacity, number of workers employed or any other criterion in determining whether the 25 per cent threshold is met.
- Where the transaction readily qualifies on an appropriate 25 per cent measure with respect to a relatively wide geographic basis (as the UK, Great Britain, England, Scotland, Wales or Northern Ireland), the OFT is able to qualify the merger on this basis even if the transaction's competitive impact is more likely to be regional or local in nature. This practice is intended to make jurisdiction relatively swift to establish. However, if the transaction does not qualify on one of these obvious bases, the issue of 'substantial part of the UK' will need consideration (see below).
- The OFT will not apply the share of supply test to capture mergers where the relationship between the merging parties is purely vertical in nature.⁴⁰

Substantial part of the UK

- 3.56** The share of supply test may be applied to the UK as a whole or to a substantial part of it. There is no statutory definition of 'a substantial part'. The House of Lords ruled in the context of similar provisions in the Fair Trading Act 1973 that, while there can be no fixed definition, the area or areas considered must be of such size, character and importance as to make it worth consideration for the purposes of merger control.⁴¹ The OFT will take the following factors into account: the size, population, social, political, economic, financial and geographic

40 See Completed acquisition by GFI Group Inc of Trayport Limited 28 May 2008 and Completed acquisition by the BUPA Group of the Cromwell Hospital 24 June 2008. In Anticipated acquisition by Odeon Cinemas Limited and Cineworld Cinemas Limited of Carlton Screen Advertising Limited 1 July 2008, the relationship between the parties was not purely vertical, and hence the share of supply test was applicable.

41 See Regina v Monopolies and Mergers Commission and another ex parte South Yorkshire Transport Limited [1993] 1 WLR 23.

42 The CC has found, applying the House of Lords' test as to whether an area was of such size, character and importance as to make it worth consideration, that the Borough of Slough represented a substantial part of the UK. In reaching this conclusion, the CC had regard to such considerations as population and economic factors, as well as the fact that the markets in which the merging parties competed were local in nature (CC: A report on the acquisition of the Co-operative Group (CWS) Limited's store at Uxbridge Road, Slough, by Tesco plc 28 November 2007).

43 See CC: A report on the acquisition by Archant Limited of the London newspapers of Independent News and Media Limited 22 September 2004, Appendix C paragraph 28.

44 As in the case of the application of the rules concerning the allocation of turnover, and save as otherwise stated in this guidance, the OFT will generally follow the guidance of the Commission as set out in section C(V) (Geographic allocation of turnover) in its Consolidated Jurisdictional Notice under Council Regulation 139/2004 on the control of concentrations between undertakings OJ 2008 C95/1 in determining when goods or services should be regarded as supplied in the UK.

significance of the specified area or areas, and whether it is (or they are) special or significant in some way.⁴²

- 3.57** In line with the approach taken previously by the CC and OFT, there is no need for the substantial part of the UK for application of the share of supply test to constitute an undivided geographic area. This interpretation gives effect to the purposes of the Act. The economic significance of a merger, in terms of a substantial lessening of competition, does not necessarily depend on whether several localities are contiguous or separated.⁴³

Supply of goods or services in the UK

- 3.58** The share of supply test requires that the merger would result in the creation or enhancement of at least a 25 per cent share of supply or acquisition of goods or services either in the UK or in a substantial part of the UK.
- 3.59** Services or goods are generally supplied in the UK where they are provided to customers who are located in the UK.⁴⁴ That is, in most circumstances, the place where competition with alternative suppliers takes place. The OFT will apply this general rule in a flexible and purposive way. In all cases, it will have regard to where relevant procurement decisions are likely to be taken and where, in turn, any competition between suppliers takes place.⁴⁵
- 3.60** In the case of sales to multinational companies, irrespective of place of incorporation, domicile or principal place of business, the general question is the presumptive location of the procurement decision. It will be a UK sale if the procurement decision is made by a business unit located in the UK and it will be foreign if such a decision is made outside the UK. Certain strategic decisions may on the facts be made at a multinational's headquarters, even if the goods are delivered, title passes, or the services supplied are outside the jurisdiction of the headquarters (for example, secondary stock exchange listings).

3.61 In the case of services with a foreign component supplied to UK end-consumers, supply will generally be in the UK if both the procurement decision (for example internet purchase) took place in the UK and it is appropriate to deem the UK as the location of competition for that customer. This would capture, for example, foreign package holidays from the UK, or services otherwise primarily directed at UK consumers, but not supply of services abroad directed at local consumers or tourists (for example directly booked accommodation or leisure services, a proportion of customers for which happened to be UK tourists who purchased these services in advance in the UK: competition for these UK customers would be deemed to take place abroad).

45 The mere fact that a supplier is located in the UK is therefore not conclusive that services are being supplied in the UK.

4 Notifying mergers to the OFT

- 4.1** Under the Act, there is no requirement to notify mergers to the OFT, regardless of whether or not the OFT would have jurisdiction to review the merger. Notification to the OFT is therefore described as ‘voluntary’ in the UK,⁴⁶ in contrast to the situation in many other jurisdictions, including the EC Merger Regulation.
- 4.2** Since notification of a qualifying merger is not mandatory under the Act, it is perfectly acceptable for parties not to notify a merger which meets the jurisdictional thresholds, and the fact that a merger has not been notified does not negatively affect the OFT’s substantive evaluation of the competitive effects of a merger.
- 4.3** Indeed, in cases that constitute a relevant merger situation solely on the basis of the turnover threshold, but where competition concerns clearly do not arise because there is no (or no material) overlap between the merging parties’ activities (and where there is no non-horizontal concern), the parties may well decide that notification to the OFT would be disproportionate and unnecessary.
- 4.4** However, in cases that do raise the possibility of competition concerns, parties should consider carefully whether to notify the merger to the OFT. In making this choice, they should be aware that:
- the OFT may well become aware of the transaction as a result of its own market intelligence functions (including through the receipt of complaints), and
 - a decision not to notify the OFT carries particular risks once the merger has been completed.
- 4.5** These considerations are discussed in turn below. The OFT’s obligation under section 107(1)(a) of the Act to publish any decision it makes about whether or not to refer means that, where the parties voluntarily provide information to the OFT about whether a merger in the public domain qualifies for investigation and/or would create competition concerns, the OFT will consider itself under an obligation formally to investigate and publish a decision.

⁴⁶ The parties may, however, be asked to provide sufficient information for the OFT to be able to review the merger if the OFT chooses to investigate on its own initiative, see paragraph 4.15 below.

The OFT's market intelligence function

- 4.6** The fact that a merger has not been voluntarily notified to the OFT does not mean that the OFT will not review it.
- 4.7** The UK merger regime contemplates the possibility of merger review initiated by the OFT itself where it believes it may have jurisdiction. A significant number of the cases in which the OFT has ultimately concluded that the test for reference was met are ones in which the merger was not voluntarily notified to the OFT but where the OFT decided to investigate the case on its own initiative or following a complaint from a third party.
- 4.8** Under section 5 of the Act, the OFT is responsible for obtaining, compiling and keeping under review information about matters related to the carrying out of its functions under the Act. In order to carry out these functions, the OFT pro-actively reviews a variety of information sources, including national and representative trade press, to obtain information about anticipated and completed mergers. The OFT also maintains an active dialogue with Governmental departments and other regulatory bodies to obtain intelligence about merger activity. In addition, the OFT considers information received from third parties, most often customers and competitors of the merging parties.
- 4.9** The OFT has a dedicated Mergers Intelligence Officer responsible for monitoring non-notified merger activity and liaising with other competition authorities. That person can be contacted confidentially at mergers.intelligence@oft.gsi.gov.uk if any interested party wishes to make the OFT aware of a merger that it considers might potentially be anti-competitive.

Complaints handling

- 4.10** The OFT has a responsibility to keep merger activity under review and is under a duty to refer certain mergers to the CC. However, it does not follow that the OFT must, or will, follow-up and investigate every complaint relating to a non-notified merger (even where it is clear that the OFT would have jurisdiction), as this would undermine the benefits of the voluntary regime. The OFT will not investigate a merger simply because a complaint has been made to it.

- 4.11** Rather, the OFT will judge each complaint on its merits. It will have regard to the strength of the complaint having regard to all evidence provided. Although the OFT will take account of all credible available evidence, it will also be mindful of the incentives of the complainant in the context of the merger and candidate theories of competitive harm in question.
- 4.12** Customer concerns are treated, all else equal, as particularly significant because customers will suffer from an anti-competitive merger.⁴⁷ Conversely, where a competitor complains that a horizontal merger will dampen competition, its interest would generally be directly opposite to those of customers and consumers, because a rival would tend to benefit from less competition, and suffer from greater competition, post-merger. Equally, rival bidders may try to use the regulatory process to frustrate or delay a benign or pro-competitive transaction that the parties – for good reason – chose not to notify.
- 4.13** The OFT will therefore take into account the need not to burden competitively benign or pro-competitive mergers with own-initiative investigations in appropriate cases, in order to preserve a key advantage of the voluntary regime. Equally, the fact that a complainant might decide to challenge a clearance decision will not influence the OFT’s decision on whether or not the duty to refer is met.
- 4.14** The OFT will also not act upon explicit non-competition concerns based on legitimate public policy issues outside the OFT’s remit, such as protection of UK employment and environmental issues, among others. In all cases, the question for the OFT is whether the transaction might be one that creates the realistic prospect of a substantial lessening of competition. However, the OFT may also take into account the existence of its statutory discretions (including its ‘*de minimis*’ exception to the duty to refer) not to refer when determining which cases to investigate.

⁴⁷ In a situation where a non-horizontal merger raises concerns, competitor concerns will be more closely aligned with the interests of customers.

Enquiry Letters

- 4.15** In cases where the merger is not voluntarily notified to the OFT, but where the OFT learns of it through another route, the OFT will consider whether to investigate the case by sending the acquiring party or parties an enquiry letter. In making a decision whether to send an

enquiry letter, the OFT will consider whether the case in question is one in which there is a reasonable prospect that its duty to refer may be met. As discussed above, the OFT will not send an enquiry letter merely because it has received an unsubstantiated complaint about a merger from a third party.

- 4.16** The purpose of the initial enquiry letter is for the OFT to establish whether the jurisdictional thresholds under the Act are met and to ascertain information about the transaction. The extent of information requested by the OFT in its enquiry letter will vary depending on the circumstances of the case in question. If the response to the enquiry letter contains all the information that the OFT needs to begin its investigation, the OFT will then review the merger as if it had been notified, and will begin its administrative timetable (see paragraph 4.65 below) from the working day after the response that amounts to a satisfactory submission has been received. Where the response to the enquiry letter provides information on jurisdiction, but does not provide all the information required for a submission, the OFT would need to follow-up with questions on the impact of the merger situation or a request for a full submission. In this scenario, the administrative timetable would generally begin only once the necessary additional information had been received.
- 4.17** Parties receiving an enquiry letter are encouraged to respond on a timely basis, and, in any event, within the specified deadline in the enquiry letter. Where the merger has already completed at the time the OFT sends the enquiry letter, it is likely to request the information under a statutory notice under section 31 of the Act in order to suspend the four month statutory timetable in respect of completed mergers (see paragraph 6.3 below). This does not mean, however, that the OFT will wait indefinitely for a satisfactory submission before starting its investigation. Particularly in completed mergers raising the risk of pre-emptive action, the OFT reserves the right to commence its investigation if the parties have failed to provide a satisfactory submission within a reasonable time following receipt of an enquiry letter. In extreme cases, where the parties effectively refuse to provide a satisfactory submission, the OFT will commence its investigation and then send the parties an issues letter if appropriate.

- 4.18** Under section 107(1)(a) of the Act, the OFT is required to publish any decision it makes to refer or not to refer. For this reason, in all cases in which the OFT sends an enquiry letter on its own initiative, it will proceed to complete its investigation and ultimately publish its decision.
- 4.19** In situations where the OFT decides after its investigation that the merger does not qualify for investigation under the Act, the OFT will publish a decision to this effect. In other cases, the decision will be whether or not to refer the case to the CC.
- 4.20** The template for the enquiry letter used by the OFT when seeking information about a merger that has been drawn to its attention other than by the parties to the merger, is available on the OFT's website (www.offt.gov.uk/shared_offt/business_leaflets/general/enquirysampleletter.pdf) although, as stated above, additional or more specific information may be requested in individual cases.

Risks to the parties of not notifying completed mergers

- 4.21** The decision whether or not to notify a merger to the OFT is particularly important in cases where the merger has been, or is about to be, completed.
- 4.22** The fact that a merger has been completed does not prevent the OFT from investigating and referring it to the CC for possible remedial action, or accepting undertakings in lieu of reference, even if the merger is a relatively small transaction. The OFT will not treat completed mergers more favourably than anticipated mergers.
- 4.23** The OFT may make a reference to the CC in completed merger cases up to four months after the merger completed, unless the merger took place without having been made public and without the OFT being informed of it (in which case the four month period only starts from the earlier of the date on which material facts about the merger were made public or the time the OFT was informed of it – see paragraph 3.44 above). The fact that a merger has recently completed should therefore not deter third parties from informing the OFT about a transaction they consider may be anti-competitive.

4.24 For the merging parties, there are several important considerations that they should bear in mind in the context of completed mergers.

- First, as discussed in detail in paragraphs 6.23 to 6.45 below, the OFT is likely to seek initial undertakings from the parties in all completed merger cases carrying the risk of pre-emptive action where it has reasonable grounds for suspecting that a relevant merger situation has been created and where there are preliminary indications that the merger raises or is likely to raise competition concerns. If the parties are not prepared to enter into such undertakings promptly, the OFT is likely to impose an order where the statutory threshold for doing so is met. Initial undertakings, or an initial order, are intended to prevent the parties from integrating, or further integrating, the merging businesses in order to preserve the CC's remedial powers. They are appropriate until the merger is cleared or remedial action is taken.
- Second, completing a merger without first obtaining clearance from the OFT carries the risk that the completed transaction may be ordered to be undone following a reference to, and an adverse finding by, the CC. This has occurred under the Act in a number of cases.⁴⁸ It is important for merging parties to understand that the fact that a merger has been completed does not reduce the likelihood of the OFT finding that the test for reference is met and of the merger being referred to the CC. Furthermore, parties should be aware that, when considering remedies in the context of a completed merger, the CC will not normally consider the costs of divestment to the parties as it is open to the parties to make merger proposals conditional on competition authorities' approval.⁴⁹
- Third, in choosing not to notify a transaction to the OFT, the parties may, in cases where the four-month statutory time period is an issue, reduce the time available to the OFT for review of the transaction. In complex cases, this limitation can impact materially on the OFT's ability to be able to conclude within the available time that the test for reference to the CC is not met so that the transaction may be cleared unconditionally without the need for a CC investigation.

48 See for example CC: A report on the acquisition of ABI Building Data Ltd by Emap plc 26 January 2005.

49 See CC Merger Remedies: Competition Commission Guidelines CC8 November 2008, paragraph 1.10.

Informing the OFT about mergers

4.25 Companies and their advisers are encouraged to contact the OFT at an early opportunity to discuss the application of the Act to a merger situation, particularly in cases where competition concerns cannot easily be ruled out. Contact details for the OFT’s Mergers Group are provided at the end of this booklet.

4.26 There are a number of different ways in which parties to a merger may ask the OFT to consider the merger. These are:

- informal advice
- pre-notification discussions
- notification using a statutory merger notice (previously referred to as ‘statutory voluntary pre-notification’), and
- notification by way of informal submission.

4.27 Informal advice is used to obtain information about the OFT’s views of likely competition issues in a future transaction, but does not trigger an actual investigation leading to a public decision. Pre-notification discussions are a preliminary stage for cases where the parties wish to proceed to notify the merger. The statutory merger notice and the informal submission are the two (alternative) forms of making an actual notification of a merger to the OFT. Each of these routes is described below.

Informal advice (IA)

4.28 In planning mergers and acquisitions, it is for parties and their advisers to assess whether transactions might give rise to competition concerns. However, in order to assist the planning and consideration by companies and their advisers of future mergers, the Group is prepared to give advice on an informal basis on competition issues⁵⁰ (and/or, where relevant, jurisdictional issues) arising out of a prospective merger situation that has not yet been made public, where certain conditions are met, as outlined below.⁵¹

⁵⁰ Including how the OFT would approach the counterfactual in the particular case, for example as to whether one of the merging businesses can be regarded as a ‘failing firm’.

⁵¹ The IA process can also provide some indication of the type of information that the OFT would seek in a public notification and whether undertakings in lieu of a reference might be acceptable. Indeed, the OFT will discuss information requirements and the potential availability of remedies in all cases in the context of pre-notification discussions (ie outside the confines of the IA process).

Informal advice – principles

- 4.29** The following are screening principles for IA applications, based on the OFT's need to be discriminating in the work it takes on and to deploy senior experienced staff to maximum effect. In the merger control context, such resources are primarily focused on managing how the OFT evaluates around 100 anticipated and completed transactions annually to which statutory duties apply.
- 4.30 Advice is appropriate for good faith confidential transactions only.** IA is available only for transactions that are neither hypothetical ('too soon for IA') nor in the public domain ('too late for IA'). In assessing whether a confidential transaction is suitable for the IA process, the OFT will generally expect to be satisfied that there is a good faith intention to proceed as evidenced by a likely ability to do so, having regard to (i) adequate financing; and (ii) heads of agreement or similar for agreed transactions; or (iii) evidence of board-level consideration by the acquirer where circumstances required IA prior to notifying the target. The factors listed above are non-exhaustive and the OFT will be open to persuasion that a specific good faith proposal is appropriate for IA consideration, for example when a trade purchaser is genuinely considering making a bid in the context of an auction situation.
- 4.31 Advice is useful and appropriate only when there is a genuine issue.** The OFT believes it can materially assist business, and justify use of its own resources for IA, only when its duty to refer is a genuine issue. It sees no value to business or the taxpayer in accepting invitations to endorse the propositions of advisers that a transaction raises no such issue. Parties, with the exception of pro bono cases, are well-placed to rely on proper external advice in such cases; as the UK regime is voluntary, they are of course under no obligation to notify their transaction to the OFT.
- 4.32** In practical terms, the OFT will provide up-front assistance where it can engage with a candid presentation of an issue – on 'without prejudice' terms. In order to do that advisers will therefore be expected to articulate the theory of harm that the OFT might reasonably rely upon as a credible candidate case for reference. This standard is that

52 The OFT does not automatically send an issues letter in all notified cases that have previously been the subject of IA, as this decision is taken depending in significant part on the information that is received in response to the OFT's market consultation.

employed within the OFT to decide whether a notified case should be subject to the OFT's in depth case review meeting (CRM) procedure, including the issues meeting process (see paragraph 6.48 below).⁵² This standard will not be met simply through a claim that the client is 'very risk averse', or that 'third parties might complain'. Nor should self-incrimination be an issue. The OFT has a record of dealing with parties' arguments in CRM cases, including remedies proposals, on a without prejudice basis: CRM cases are often cleared (and proposed undertakings in lieu left aside) because the OFT decided it had no duty to refer.

4.33 Where the OFT is not satisfied that the request for IA relates to a transaction that does raise a genuine issue as to referral, the request will be rejected save in exceptional circumstances (such as in pro bono cases, involving public bodies or private enterprises unable to afford external competition law advice) as and when resources permit.

4.34 Delivery and content of advice will be tailored to assist business most. The OFT will provide a bespoke response to an IA application according to what, in its view, is proportionate and would most the parties in the circumstances. The OFT may offer a quick over-the-phone service where a protracted meetings-based process would simply entail delay and cost to the parties. At all times when IA is given, the OFT will provide as comprehensive and useful advice as it can. However, where OFT officials possess no particular insights that the parties and their advisers lack and/or the analysis turns particularly on the market test, the advice will be to this effect.

4.35 Two examples are set out below.

- **Example – OFT advises that it cannot offer meaningful guidance beyond that available in published practice.** An IA application relates to a market for which suitable guidance in the form of previous OFT, CC or other decisional practice exists. The OFT advises by phone to this effect, adding any additional insights it feels it can offer prior to evaluation of any third party evidence. It offers a pre-notification conference call with the case team in due course to discuss a draft notification and suggests evidence which may be appropriate to shed light on the key competition issues of the case.

- **Example – OFT advises that third party evidence is likely to be decisive as to its duty to refer.** An IA application presents a merger as a '4:3' in a declining market with high entry barriers and a sophisticated, concentrated customer base. It argues that buyer power alone is sufficient to avoid a reference outcome, but seeks the OFT's view. The OFT's advice is as follows: (i) primary weight would be given by the OFT to customers' own views on this point, substantiated with evidence; (ii) the parties' best course of action in the interim would be to gather credible evidence that buyers have leveraged such 'power' – by threatening to self-supply, sponsor entry or retaliate in other markets as the case may be – in past pricing negotiations; (iii) at the end of its inquiry, the OFT would weigh the probative value of such 'rebuttal' evidence against evidence supporting concerns in assessing whether it had the duty to refer. A pre-notification meeting with the case team is offered for when the parties have gathered the relevant evidence.

4.36 An application for IA will normally seek the OFT's substantive view as to the likelihood of the case being referred to the CC. However, where the above principles are met, the OFT will provide advice on jurisdictional issues – such as share of supply test or material influence questions or questions on case allocation between the European Commission and the OFT – on these issues alone, or indeed along with advice on the substantive issues raising the genuine issue of a duty to refer. The OFT will not, however, give advice on jurisdictional issues in cases that do not raise the genuine issue of a duty to refer given that this would not be a sensible use of resources in a merger regime with voluntary notification.

4.37 The limitations of the IA process⁵³ mean it is unsuitable, however, for the OFT to advise on the decisive legal question of whether the structure of a transaction, designed to fall outside the Water Industry Act 1991 regime, is nonetheless caught by the relevant automatic reference provisions (see paragraph 10.1 below). Pre-notification is recommended in such a case.

⁵³ In particular, the fact that the IA process is simply the non-binding view of the OFT officials giving the advice – not that of the OFT decision maker – and the fact that the OFT does not consider that the case team are in a materially better position than external lawyers to advise on whether a particular corporate structure triggers a mandatory reference to the CC.

Informal advice – procedures and caveats

4.38 Applications – Parties should address all IA applications to the case officer responsible for the relevant sector. The request should be presented in a clear, concise executive summary format of no more than five pages in length, covering:

- the suitability of the proposed transaction for IA treatment by reference to the principles set out in paragraphs 4.30 to 4.32 above
- the theory of harm underlying a credible candidate case for reference, leading the OFT to believe the duty to refer is a genuine issue, and
- the key substantive issue(s) – and/or where applicable, jurisdictional issues – on which the parties seek guidance.

4.39 Timing – while there is no standard timetable for the provision of IA, the OFT will endeavour to indicate whether it will accept or reject an IA application within five working days of receipt of the application. Where IA is to be given immediately at the conclusion of a meeting, the OFT will endeavour to schedule that meeting within 10 working days of receipt of the original application. Urgent cases will be handled more swiftly if (i) adequately justified by the parties and (ii) the diaries of relevant OFT staff permit.

4.40 Caveats – the following conditions and caveats to IA apply.

- First, IA is solely the view of the OFT staff in the Mergers Group. IA will usually be given by a Deputy Director or another senior member of the Group, accompanied by a case officer in the team responsible for the relevant industry sector and an economist. IA is not given by the Chairman or any other member of the OFT's Board. It does not bind the OFT, and creates no expectations as to the outcome at the public stage of any transaction.
- Second, both the content of IA and the fact that a party has applied for it is strictly confidential to the party or parties seeking that advice and their legal advisers, even after the transaction becomes public. The OFT would be concerned by any breach of trust in this respect – either by the companies concerned or by their advisers – and they

might take the view that they could not offer those responsible any such IA in the future. This restriction applies even where only one party to a transaction seeks IA, as the advice should not be revealed by the recipient to the other party. The OFT will, however, normally be willing on request to inform orally the other party of the terms of the IA given. In all cases, the guidance given by the OFT is confidential and is only for the Board members, senior executive officers and general counsel (and not individual shareholders) of the company/companies making the request and the legal/financial advisers that are privy to the request.⁵⁴

- Third, the OFT is unable to test the parties' submissions to verify information provided in an IA application: any advice given is based on the assumed accuracy of that information. For this reason, although the information provided should be brief, the quality and accuracy of the Group's advice will, to a large extent, reflect the quality and accuracy of the information provided.
- Fourth, the IA process is 'one-shot' and not iterative, though subsequent pre-notification contacts may be encouraged (see paragraphs 4.42 to 4.48 below).

54 In case of doubt, parties should confirm with the OFT the identity of the persons with whom they are permitted to share the advice received.

4.41 As a condition of seeking and obtaining IA, once parties have received the Group's IA, they agree to inform the relevant case officer if and when the proposed transaction goes ahead and becomes public knowledge. The OFT and its staff will respect the confidential nature of the IA procedure, and no public announcement is ever made about the outcome. Nor is any indication given that a request for IA has been made in a given case. Furthermore, discussions on IA remain without prejudice to the handling and investigation of the case if formally notified.

Pre-notification discussions

4.42 Pre-notification discussions take place when the parties to a merger have decided to notify the OFT and wish to engage with it, typically on the contents of a draft notification, prior to formal submission. In the Group's experience, use of the pre-notification phase to discuss an intended notification with the case team on a confidential basis is an important part of the whole merger review process. It is in the interests of both the OFT and the parties to any transaction that notifications

are complete at the time of an actual submission (whether by way of statutory merger notice or informal submission). For companies planning to notify a merger, either as a statutory merger notice or an informal submission, the Group therefore strongly encourages parties to contact the OFT to engage in pre-notification discussions.

4.43 Pre-notification contacts benefit the parties, and often the OFT, by serving, for example, to:

- educate the case team where markets are complex and/or unfamiliar (in particular through discussions with the business people of the merging parties)
- frame the transaction, including its rationale and efficiencies, in a realistic context early on
- clarify what information and evidence the OFT will require to deem a submission satisfactory or a statutory merger notice complete, or will request early in the review procedure
- identify useful items of evidence that may assist the parties' case, including internal, day-to-day documentation that may be relevant
- potentially avoid or minimise burdensome information requests
- be an additional forum for informal dialogue on the OFT's likely approach to consideration of a novel issue or the assessment of particular competition concerns (although pre-notification discussions are not intended to cover an assessment on the substance of the case by the OFT and applications will not be treated as applications for IA, for which the separate procedure described in paragraphs 4.28 to 4.41 above applies)
- promote agreement on pragmatic methodological solutions to tackling issues, for example, isochrone analysis in local retail cases, such as grocery and cinemas mergers, road/rail overlap and profitability data in transport cases, use and design of customer surveys, calculation of diversion ratios, and so on, and
- in appropriate cases, allow for consideration of the structuring of undertakings in lieu options. The OFT is particularly ready to engage in early dialogue with parties where they acknowledge that their transaction may raise a competition issue and seek advice on structural remedies to resolve it (see paragraph 8.9 below).

- 4.44** The pre-notification process is available for all transactions regardless of whether or not they are in the public domain. The OFT does not make public the fact that it is in pre-notification discussions on a case. However, the pre-notification process is not available for transactions that are hypothetical and the OFT will generally expect to be satisfied that there is a good faith intention to proceed as evidenced by, for example, adequate financing, heads of agreements or similar, or evidence of board-level consideration.
- 4.45** Pre-notification discussions will generally include a review of an actual draft notification document. As well as exploring the types of information needed to provide a complete submission (see chapter 5), this discussion may also identify additional useful information that the OFT would look for in a particular case, the provision of which might accelerate and/or facilitate the OFT's review of a merger. Draft notifications should be as complete as possible at the time of their submission to the OFT in order to maximise the value of feedback from the Mergers Group.
- 4.46** In appropriate cases, pre-notification discussions also provide an opportunity for the parties to engage constructively with the OFT on the question of which competition authority is best placed to review the merger. If the transaction does not have a Community dimension, the parties may wish to discuss the possibility of a pre-notification referral to the Commission under Article 4(5) of the EC Merger Regulation. Alternatively, where the transaction does have a Community dimension, the parties may wish to discuss with the OFT whether the OFT is best-placed to review the transaction and whether a pre-notification referral request (under Article 4(4) of the EC Merger Regulation) or a post-notification referral request (under Article 9 of the EC Merger Regulation) is appropriate. The OFT can provide guidance to parties on the referral processes involved (see further chapter 11 below).⁵⁵
- 4.47** In the first instance, parties seeking to hold pre-notification discussions should contact the case officer responsible for the relevant industry sector. These details can be found on the OFT's website at www.of.gov.uk/advice_and_resources/resource_base/Mergers_home/contacts

⁵⁵ The discussion as to which authority would be best placed to review a transaction could take place either in the context of IA (in respect of a potential future transaction) or pre-notification discussion (in respect of a transaction that is proceeding).

4.48 The case team will endeavour to review submissions and revert to the parties within a reasonable time frame; as a guide, this is generally expected to be some five to 10 working days from receipt, although the team will endeavour to accommodate City Code on Takeovers and Mergers (the City Code) or other pressing timetable concerns whenever possible. Where a pre-notification meeting or conference call is desirable, the case team will schedule one, generally chaired by the case officer or a Deputy Director where appropriate; otherwise pre-notification contacts will proceed on the basis of phone, email and formal written contacts as required.

Notifying the OFT about mergers in the public domain

4.49 Once a merger is announced, and thereby becomes public knowledge, the companies concerned may notify their final submission to the OFT.⁵⁶ Where the parties have not signed a share purchase agreement or equivalent, the OFT will generally expect to be satisfied that there is a good faith intention to proceed, as evidenced by, for example, adequate financing, heads of agreements or similar, or evidence of board-level consideration. In the case of a public bid, the OFT will expect at least a public announcement of a firm intention to make an offer or the announcement of a possible offer.⁵⁷

4.50 Any submission the OFT receives must be clear and complete, setting out the terms of the transaction and outlining any competition issues that may be foreseen (see chapter 5). On receipt of such a submission, the OFT nominates a specific case officer (to take primary responsibility for dealing with the case) and an economist. The name of the case officer is passed to the individual who made the submission. In subsequent exchanges, the merging parties and their representatives should regard that officer as their point of contact within the OFT. The work of individual case officers is co-ordinated and overseen by the Deputy Directors and Director of the Group who would normally seek a meeting with the parties if there appeared to be significant competition issues at stake (see chapter 6).

4.51 The notifying parties can make use of one of two processes to notify a merger to the OFT for investigation: (a) a standard statutory merger notice form,⁵⁸ which lays down a statutory timetable that guarantees a

56 Parties are not able to notify transactions to the OFT that they wish to keep confidential given that the OFT issues a public invitation to comment at the start of its investigation. The OFT is therefore not able to begin its administrative timetable for review of the case until the merger has been announced.

57 Corresponding with Rules 2.5 and 2.4 of the Takeover Code respectively.

58 Available as a downloadable document from the OFT website at www.of.gov.uk/shared_of/business_leaflets/general/mergernotice03.pdf

decision on reference to the CC within 30 working days⁵⁹ (with some exceptions) or; (b) an informal written submission, which does not give the parties the benefit of a statutory timetable but under which the (non-binding) administrative target for the OFT to announce its decision is 40 working days. These notification processes are discussed below.

The statutory merger notice

- 4.52** The statutory merger notice procedure⁶⁰ provides that an anticipated merger in the public domain may be considered by the OFT within 20 working days, with a maximum extension of 10 working days at the OFT's discretion (section 97 of the Act). Subject to some exceptions, the merger would be automatically cleared where no reference has been made by the end of that period. A fee is payable at the time of submission (see chapter 7).
- 4.53** This procedure may be used to provide formal notification only of anticipated (ie non-completed) mergers that have already been made public. It cannot be used for completed mergers, nor for anticipated mergers that have not yet been made public. The procedures under the statutory merger notice are described more fully in Annexe A.
- 4.54** Although the benefits of the statutory merger notice procedure are available in all anticipated merger cases that have been made public, it is most suitable for transactions that do not raise material anti-competitive concerns but where the certainty of regulatory clearance is required within a fixed time period.⁶¹ The statutory merger notice is therefore most obviously suited for transactions where:
- there are no horizontal overlaps between the parties' activities and they are not active on upstream, downstream or neighbouring markets, or
 - the parties' activities overlap horizontally but their combined share is below 15 per cent on any conceivable relevant market, or
 - the parties are only active upstream or downstream or in a neighbouring market from each other and their share on each of those markets is below 25 per cent.

59 Assuming that the OFT has extended the 20 working day deadline by the permitted additional 10 working days.

60 This procedure was introduced under the Companies Act 1989, amended by the Fair Trading Act (Amendment) (Mergers Pre-notification) Regulations 1994 (SI 1994/1934) and subsequently amended by Enterprise Act 2002 (Merger Pre-notification) Regulations 2003 SI 2003/1369. It was therefore previously referred to as 'statutory voluntary pre-notification'.

61 In many cases not raising material competition concerns, the parties may decide not to notify at all (see paragraph 4.2 above).

- 4.55** The short time period available for review by the OFT means that the statutory merger notice procedure is not ideally suited for mergers that appear to raise material competition issues, which will generally include cases where reasoned and substantiated complaints are expected. Normally, they are also not suitable for cases referred from the Commission to the UK under Articles 4(4) or 9 of the EC Merger Regulation – see paragraphs 11.14 to 11.29 below – given that these cases may raise competition concerns.
- 4.56** In cases that do raise material competition issues, it remains open to the parties to notify by way of statutory merger notice where the transaction is anticipated and in the public domain. However, parties should understand that by choosing – potentially for understandable commercial reasons – to give the OFT a more limited period of time in which to seek to satisfy itself that the test for reference is not met, they risk not maximising their chances of a phase one outcome. The benefits of a shorter (and more certain) phase one timetable must be set against this. Further, this risk may be increased where the parties have not engaged in appropriate pre-notification discussions with the OFT before submitting a statutory merger notice.
- 4.57** Where parties are unsure as to the suitability of the statutory merger notice procedure in any particular case, advice can be requested from the case officer responsible for the sector concerned. During such discussions, the case officer may be able to provide assistance about how the information requirements of the statutory merger notice may most appropriately be satisfied in the case in question.
- 4.58** To benefit from the deadlines under the statutory merger notice procedure, the notifying party must use the prescribed merger notice to set out the information that the OFT will require about the transaction, with details of the markets involved. Copies of the form, with further guidance on current procedures, may be obtained from the OFT website.⁶² The completed form may be submitted by post, by hand, by fax or by email, together with the appropriate fee (see chapter 7) made payable to the OFT. If the appropriate fee is transmitted to the OFT via the Bankers Automated Clearing Systems (BACS) system, information relating to this transfer must be forwarded to the case officer at the same time as the completed merger notice so that the

⁶² www.offt.gov.uk/shared_offt/business_Leaflets/general/mergernotice03.pdf

payment can be matched with the appropriate submission. Any delay in matching the transferred fee with the statutory merger notice may result in a delay in registering the notice and hence a delay in the statutory period starting to run.

- 4.59** The statutory merger notice itself has been designed to provide the OFT, in appropriate cases suitable for the statutory procedure, with sufficient information to allow it to assess, at an early stage, whether there are any grounds to make a reference.
- 4.60** In order to meet the deadlines imposed by the statutory merger notice procedure, the OFT effectively prioritises such cases over other cases simultaneously under consideration by the Group. The OFT will therefore not encourage parties to withdraw a statutory merger notice at a late stage of the OFT's review in order to provide additional time for consideration of evidence (for example, where third party concerns have been received or material issues have been raised during the course of an investigation that might have been able to be satisfactorily addressed under a longer timetable).
- 4.61** Although parties are entitled to withdraw the statutory merger notice (see paragraph A.13 of Annexe A), and to re-notify as an informal submission, the parties should have no expectation that their case will necessarily be decided within 40 working days from the date of submission of the original merger notice. To allow such an expectation would create improper incentives that risks effectively penalising other parties that filed an informal submission on the administrative timetable and did not receive 'priority' statutory treatment for the first 20-30 working days. It does not follow from this that the OFT will re-start the clock from zero whenever the parties do withdraw and re-notify using an informal submission; equally, it does not follow (including where the case will involve an issues letter and issues meeting) that the parties will transfer to the equivalent stage of the administrative timetable. Rather, the OFT will take all the circumstances of the case and its current caseload into account in determining its future timetable in that situation.
- 4.62** In cases where the parties do withdraw a statutory merger notice and re-notify using an informal submission, no extra fee will be payable (see paragraph 7.7 below) and no additional written submission would normally be required on conversion.

Informal submissions / own-initiative investigations

- 4.63** Given the constraints of the statutory merger notice procedure, merging parties and their advisers generally prefer to advise the OFT of UK mergers by means of an ‘informal submission’. Indeed, this is the only available method of notification for completed mergers. While there is no prescribed form for such submissions, chapter 5 of this guidance contains advice on the information that will normally be required in such submissions.
- 4.64** Where the OFT sends an enquiry letter to the parties on its own initiative (see paragraphs 4.15 to 4.20 above), the information it requests, potentially by way of additional information requests,⁶³ will ultimately be similar to that which the parties would have provided had they chosen to notify the transaction by way of informal submission. For this reason, a satisfactory response from the parties in such situations (once the case officer has confirmed that the OFT has sufficient information to begin its administrative timetable) is treated as being akin to an informal submission.
- 4.65** Except for the four-month statutory deadline for completed mergers, there is no formal review timetable when notification is made by informal submission. However, the OFT’s practice is that, on receipt of a satisfactory complete submission, it would generally endeavour to reach a decision within 40 working days by way of administrative target.
- 4.66** Where merging parties request that the OFT should not rigidly adhere to its administrative timetable, the OFT considers it appropriate to treat such requests as equating to an extension of the 40 working day deadline. In the exceptional circumstances where the administrative deadline is so extended, the extension is likely to be for no more than five to 10 working days, and the OFT would in these circumstances regard meeting the deadline, as extended, as having complied with its administrative timetable.
- 4.67** Save where requested to do so by the notifying party, the OFT will not count working days between 27 December and 1 January (inclusive) for the purposes of its administrative timetable calculations. Similarly, the OFT will seek to avoid sending out information requests to merging parties over this period.

⁶³ This will be the case where the parties’ response to the enquiry letter covers jurisdictional issues but is insufficient to enable the OFT to begin its investigation of the competitive impact of the merger.

- 4.68** Where merging parties request that a decision is made more quickly than the standard administrative timetable, the OFT will take account of this when conducting its review. While it will try to speed up the procedures in such a case, this may not always be possible where the demands of the particular case make it impracticable to accelerate the process or where the OFT's existing caseload means that this is not feasible. If a quick decision is needed, the initial submission should clearly explain why the case is urgent, with evidence if available, and why the submission was not made earlier. In such cases, the OFT would expect the merging parties to be particularly alert to the importance of a full and complete merger submission and to very prompt responses to additional requests for information.
- 4.69** The parties should also inform the OFT if the merger situation is covered by the City Code: in such cases, the OFT endeavours to the best of its ability to align its timetables to those envisaged in the Code.
- 4.70** With an informal submission, a fee is not payable until the OFT (or the Secretary of State in public interest cases) publishes a reference decision or publishes any decision not to make a reference (see chapter 7 below), save where the case is resolved through undertakings in lieu, where the fee becomes payable when the OFT loses its duty to refer as a result of its formal acceptance of undertakings in lieu (section 74(1) of the Act).

Fast track reference cases

- 4.71** The OFT considers that, exceptionally, it may be possible to accelerate significantly the treatment of cases for referral to the CC where this corresponds with the wishes of the merging parties and where there is sufficient evidence available to meet the OFT's statutory threshold for reference.
- 4.72** For a case to be fast tracked to reference, the OFT must have evidence in its possession at an early stage in an investigation that it believes objectively justifies a belief that the test for reference is met and the notifying parties must have requested and given consent for use of the procedure.

- 4.73** Merging parties are generally incentivised to seek to remedy competition concerns by means of undertakings in lieu where this is feasible. Candidate cases for fast track reference to the CC are therefore likely to be ‘binary’ cases, where, to the extent that the OFT does find a concern with the merger, that concern would impact on the whole or substantially all of the transaction, and not just one part (that could be resolved through structural undertakings in lieu).
- 4.74** Given that fast track reference cases will by definition be those where the parties accept that the test for reference is met (and agree to waive their normal procedural rights during phase one), the OFT will not be required to undergo all of the normal procedural steps followed when a case is referred (including issues meeting and a CRM). The OFT would therefore expect that, allowing for a reasonable third party consultation period and provided there were suitable pre-notification discussions, the overall time taken from formal notification to reference decision could be as little as 10 working days.
- 4.75** It is open to merging parties to inform the OFT that they consider their case meets the criteria for fast track reference to the CC at the time of notification or at any point during the course of the OFT’s investigation.

Completeness of submissions

- 4.76** It is important that any merger submission – whether a statutory merger notice or an informal submission – is complete. In the case of notifications using the statutory merger notice, consideration of the notified merger proposals cannot begin until the working day after the fully completed form and the appropriate fee has been received. In the case of informal submissions, the OFT’s administrative timetable normally starts on the working day after a complete submission has been received (although the OFT reserves the right, particularly in the case of completed merger cases raising the risk of pre-emptive action, to commence its investigation if the parties have failed to provide a satisfactory submission within a reasonable time following receipt of an enquiry letter – see paragraph 4.17 above). This underlines the importance in more complex cases of pre-notification discussions to consider the nature of the information that the OFT would be looking for in any submission (see paragraphs 4.42 to 4.48 above).

4.77 Where information important to a merger investigation is missing from a submission, the OFT will inform the merging parties of this fact at the earliest opportunity (and generally within five working days of receipt of the submission). As described in Annexe A, an incomplete statutory merger notice is likely to be rejected. An informal submission that does not contain all of the information reasonably required to start the OFT's investigation is not rejected as such, but the notification will not be considered effective and the OFT's administrative timetable will generally not be started until the additional information is received and the submission is deemed satisfactory (the exception being where the parties have not responded within a reasonable time period and the OFT considers it important to progress its investigation, which will particularly be the case in completed merger cases raising the risk of pre-emptive action). The OFT may opt to use its information-gathering powers (described in chapter 6) to obtain the necessary information.

Competing bids and parallel industry mergers

4.78 Where there are competing bids for the same company, the OFT tries, other factors being equal, to consider them simultaneously, but will not yield to strategic behaviour to delay review of a bid notified earlier in time. It does not necessarily follow that, because one is referred, the other or others will be also. As in the case of a single bidder, each case must be considered on its own merits.

Restrictions directly related and necessary

4.79 Mergers and ancillary restrictions to the merger are generally excluded from the prohibitions of the Competition Act 1998 under Schedule 1 of the Competition Act 1998. In July 2004, the Commission adopted an interpretive notice on ancillary restrictions – *Commission Notice on restrictions directly related and necessary to concentrations*⁶⁴ – which provides that only restrictions that are 'directly related and necessary' to the legitimate objective sought of implementing the transaction are justified and sets out a principle of self-assessment.⁶⁵

4.80 The OFT's analytical approach to ancillary restrictions generally follows the Commission notice and, in light of the guidance it contains, the Group considers that it is in principle no better placed than the

64 OJ 2005 C56/24.

65 In particular, the notice indicates that restrictions to competition should be of limited duration.

merging parties and their advisers in most cases to determine whether contractual arrangements and agreements are ancillary to a merger and, therefore, automatically excluded from the Chapter I and Chapter II prohibitions of the Competition Act 1998.

- 4.81** Accordingly, as a normal rule, the OFT will not give a view in its published decision (or to the merging parties confidentially) on whether or not a restriction is ancillary.
- 4.82** Exceptionally, at the request of the merging parties, and where the OFT considers that the request raises novel or unresolved questions giving rise to genuine uncertainty as to whether a restriction is directly related and necessary in the context of a merger situation (not covered by the principles set out in the Commission's notice), the OFT may, in the context of its merger assessment, choose to provide guidance on the ancillary nature of a restriction based on its own assessment of the issues, based on the following points.
- To enable such a request to be considered, the OFT will ask for various information to be provided and may wish to seek the views of third parties. It will be for the parties to the merger to indicate in their submission which elements of the arrangements are commercially confidential. If the OFT is unable to seek public comments, then it may be unable to express a view as to whether the restrictions are ancillary.
 - The OFT will include its assessment of whether a restriction is directly related and necessary to a merger situation in its published decision on the merger, including why it considers it appropriate to provide guidance in the case in question. In the case of a merger being considered under the statutory merger notice timetable, the timescale involved may reduce the extent of any guidance. In the case of a merger being considered under an administrative timetable, consideration of a request for guidance on ancillary restrictions may result in the OFT being unable to meet its 40 working day administrative timetable.

5 Contents of submissions

- 5.1** This chapter of the guidance is intended to assist merging parties and their advisers in compiling informal submissions to the OFT.⁶⁶ While the information set out below is neither prescriptive nor exhaustive, it will assist the OFT if, in making a submission, the parties use the headings and ordering set out in the following sections.
- 5.2** Nevertheless, it should be appreciated that the completeness ('satisfactory submission') requirements set out here are for general information and advice only and may not apply exactly in every case. The concept is a fluid one as the OFT adopts a pragmatic case by case approach. Sometimes it may be possible for the OFT to complete its competitive assessment with less extensive information than that suggested below. At other times, more extensive information may be required (for example, isochrone maps in cases that raise local overlap areas between the parties). Before a full formal submission is made, the OFT would always encourage parties to engage in preliminary discussions with the Group in order to identify the specific information it will need and to offer advice on how it can be best presented (see chapter 4 above in relation to pre-notification contacts).
- 5.3** The appropriate case officer will inform the merging parties once the submission is deemed satisfactory and the administrative timetable has commenced. This will be the first working day after a satisfactory submission has been provided. If the submission is not deemed satisfactory, the case officer will specify what information is outstanding.
- 5.4** The types of information needed by the OFT can be roughly divided into three categories: general background information, jurisdictional information, and information relevant to the substantive assessment. Each of these categories is discussed below.

⁶⁶ The information requirements for parties to benefit from the statutory merger notice procedure are set out in the merger notice form (Available at: www.offt.gov.uk/shared_offt/business_leaflets/general/mergernotice03.pdf).

General background

- 5.5** The OFT needs, first, some general information on each merger situation notified to it. A submission that did not include information on each of these areas – including supporting documents – would be unlikely to be deemed to be complete.

- **The parties.** Provide the full legal name of the parties involved, their headquarters' address and, if they are part of groups, explain their position in the group and give similar information on relevant related companies. Any parts of the acquiring group, other than the acquiring company, that carry on business which overlaps with that of the target or which have a vertical relationship with that business should be identified. Please also provide information (in sterling) for the most recently available year on the UK turnover for each of the acquiring enterprises and the enterprises to be acquired, their operating and pre-tax profits or losses and the value and nature of the consideration being paid. Please also state whether the acquiring party is a small or medium sized enterprise under the Companies Act 2006 (see paragraph 7.9 below).
- **Contacts.** Always provide a named contact, whether a representative of the notifying company or a legal/financial adviser, failing which the chief executive officer, with telephone and fax numbers and an email address. At times, the OFT may need to contact merging parties quickly.
- **Type and purpose of notification.** Please state:
 - whether the submission covers a merger that is anticipated or has already been completed
 - whether it is a finalised submission or a draft for the purposes of pre-notification discussions, and
 - on whose behalf the notification is being made.
- **Timing.** As notification is not compulsory under the Act, there is no notification deadline and mergers can be notified before or after completion. However, once an investigation has commenced the OFT in general works to the timetables set out in chapter 4 above. Include in any submission full details of the current status of the transaction, information on projected future timing (including the expected date of completion, where relevant) and the relationship between the transaction and other timing considerations (for example the City Code).

- **Summary description.** Include in any submission a summary of the transaction, stating:
 - the names of the acquiring company and the target
 - the type of transaction (for example, whether it is an agreed bid, a full takeover or the acquisition of assets or of a minority shareholding giving material influence, or whether it is a joint venture)
 - how the transaction qualifies as a relevant merger situation (that is through target UK turnover or combined share of supply)
 - a brief description of the business being acquired
 - the areas of overlap between acquirer and target, and
 - the reasons for the acquisition.
- **Supporting documentation.** Please provide:
 - two copies of all analyses, reports, studies, surveys, and any comparable documents prepared by or for any member(s) of the board of directors, or the supervisory board, or the other person(s) exercising similar functions (or to whom such functions have been delegated or entrusted), or the shareholders' meeting, for the purpose of assessing or analysing the merger with respect to market shares, competitive conditions, competitors (actual and potential), the rationale of the merger, potential for sales growth or expansion into other product or geographic markets, and/or general market conditions
 - two copies of each party's most recent (pre-merger) business plan
 - two copies of the most recent annual report and accounts of the merging enterprises and, where relevant, copies of the Offer Document and Listing Particulars and any press releases or newspaper cuttings, and
 - two copies of any other printed information that helps the OFT's understanding of the transaction or the affected sector, including documents relating to the competitive strategies pursued by each of the parties involved and/or their competitors.⁶⁷

⁶⁷ Where supporting documentation is in a foreign language, the parties are encouraged to provide a translation.

68 In particular, the parties should inform the OFT when the transaction falls under the ‘two-thirds rule’ of the EC Merger Regulation (that is, each party achieves more than two-thirds of its Community-wide turnover in the UK) – see chapter 11. This allows the OFT to compile statistical data on the operation of jurisdictional thresholds and criteria pursuant to its obligation under Article 1(4) of the EC Merger Regulation.

69 Where an overlap product is sold through distinct sales channels, please provide names and full contact details for at least the five most significant competitors (where applicable) and five top customers (by revenue) for both the acquirer and target in each sales channel.

70 The OFT discourages submission of more than two copies.

- **Notification in other jurisdictions.** Confirm whether the merger has been notified, or qualifies for notification, in other jurisdictions (in particular, in other EU Member States). The submission should also confirm that the merger falls outside the scope of the EC Merger Regulation and the reason for this,⁶⁸ or explain any uncertainties there may be.
- **Third parties.** For all cases in the public domain (that is, for all cases other than IA applications), please provide names and full contact details for at least the five most significant competitors (where applicable) and five top customers (by revenue) for both the acquirer and target in each area of overlap,⁶⁹ providing an individually named contact, with corresponding telephone and fax numbers and email address (where available). Without this information, the OFT is **unable** to commence its investigation (and its timetable). If such information is not provided in full, it can also significantly delay the investigation.

5.6 When the merger submission is sent in, there should be two copies of each document.⁷⁰ Separate rules apply to submission of merger notices which are described in Annexe A. The OFT strongly encourages notifying parties to provide electronic versions of the submission and supporting materials (in addition to hard copies) where available, the provision of which will facilitate the effective handling of the OFT’s review.

5.7 In addition to these general matters, the merging parties should also provide detailed information necessary to assess whether or not the merger qualifies for investigation under the Act, and, if so, whether it creates a realistic prospect of a substantial lessening of competition (see below).

Jurisdiction

5.8 The OFT’s first task is to determine whether, in its view, it is or may be the case that a relevant merger situation has been created or arrangements are in progress or in contemplation which, if carried into effect, will result in the creation of a relevant merger situation. Essentially, it needs information to satisfy itself that two or more enterprises have ceased or will cease to be distinct; if completed,

that the merger did not take place more than four months prior to the date of the decision on reference (or, if later, to the date on which the merger was made public);⁷¹ and that the merger meets either the turnover test or the share of supply test. Full details of each of these criteria are set out in chapter 3 above.

71 See paragraphs 3.44 and 3.45 above on when a merger has been made public for the purposes of section 24 of the Act.

5.9 Where there is a genuine issue over jurisdiction (including whether the Commission is better placed to review a transaction), a submission will not be deemed satisfactory until information has been received enabling preliminary determination of the issue. For example, where the parties have been informed by the OFT during pre-notification discussions that it is considering making a request under Article 22 of the EC Merger Regulation, European market shares will be required, until the provision of which the non-statutory administrative timetable will not start. (See chapter 11 for details on the timing issues under Article 22.) If issues of jurisdiction are raised after the investigation has started in relation to which sufficient information has not already been provided, the OFT retains a discretion to re-set the administrative clock back to zero in exceptional cases.

Information required for substantive assessment

5.10 The OFT is under a duty to refer a merger to the CC if it believes that it is or may be the case that a merger has resulted or may be expected to result in a substantial lessening of competition.

5.11 Detailed information on the substantive test for mergers, and how the OFT carries out its substantive assessment, is provided in the OFT publications *Mergers – substantive assessment guidance* (OFT516) and *Guidance note revising ‘Mergers – substantive assessment guidance’* (OFT516a)⁷² and *Revision to Mergers – substantive assessment guidance – Exception to the duty to refer: markets of insufficient importance* (OFT516b)⁷³ and is not repeated here. However, the OFT will expect to see information on each of the following areas in its submission:

- whether the merger is horizontal, vertical or conglomerate in nature
- the appropriate counterfactual, including evidence supportive of any claims made (including on exiting / failing firm)

72 These publications are expected to be superseded by the forthcoming UK Merger Assessment Guidelines, published jointly with the CC.

73 The OFT intends to publish separate guidance on its exceptions to the duty to refer and undertakings in lieu.

74 For further information on this topic, see The Competition Act 1998 – *Market Definition* (OFT403), March 1999.

75 A breakdown of market shares in terms of volume rather than value may be acceptable where value figures are not readily available or where volume is thought to provide a more useful basis for analysis.

- information on market definition,⁷⁴ including information on demand- and supply-side substitutability from each of a product and geographic perspective
- the nature and extent of competition in the market, including by reference to the closeness of competition between the parties
- information on the relative competitive constraint posed by the principal other suppliers in the market
- the extent to which there is a shortage or surplus of capacity in the relevant market and the extent to which the parties have control of that surplus capacity
- information on any horizontal overlaps between the merging parties, including for each of the relevant markets a valuation of the total market;⁷⁵ the figures supplied should normally be those for the most recent year for which they are available; if market shares vary significantly from year to year, however, information for several years may be more useful; if the market is thought to be wider than the UK, it is helpful to have separate figures for the domestic market and for imports, segmented by supplier if possible, and exports
- information on any vertical links between the parties and their effects where one of the merging businesses has a share of 10 per cent or more in an ‘upstream’ or ‘downstream’ market
- in cases where there are horizontal overlaps or vertical links between the parties, and where the combined shares of the parties in the relevant market are 15 per cent or more in the case of horizontal overlaps, or where the market share of one party at either level is 25 per cent or more in the case of vertical links, information on barriers to entry and the cost of entry, including information on whether the market is growing or contracting and the history of entry and exit (new entrants and those leaving the market in the last five to ten years)
- information on buyer power, including the proportion of the merging parties’ sales accounted for by the main customers, together with any evidence of the types of strategies used by customers to constrain prices, and

- where relevant, information on customer benefits arising from the merger.

Other background information

5.12 The merging parties may, of course, provide any other information they consider relevant. For example, references to earlier CC reports dealing with the same markets, contacts with other government departments or regulators about the merger, either because they have responsibilities in the relevant areas or because they are customers, and any contacts with overseas competition authorities. The merging parties are also welcome to give their own views on the competition implications or any other effects of the merger.

6 The assessment process

6.1 This chapter of the guidance provides a more detailed account of certain aspects of the OFT's assessment process. It first explains how the OFT may gather supplementary information from the merging parties to that received in the initial submission. It also describes the process for verifying information provided with third parties. It details how the OFT will use its powers to accept initial undertakings, or to make initial orders, in completed mergers. The decision making process and publication requirement are then described, as is the exchange of information within the European Competition Authorities Network.

Information gathering powers

6.2 Sometimes the OFT may need more, or more comprehensive, information from the merging parties than is provided in the initial merger notification (even though that initial submission is sufficient to be deemed complete for the purposes of commencing the OFT's review and timetable) to allow it to make a decision on reference. The OFT asks for any such additional data, information or documents as soon as it is clear they will be necessary, but, if the timetables are to be met, replies also have to be supplied quickly. Requests for such information normally identify a short deadline for a full response, which might be as short as one business day where necessary. If that deadline cannot be met, it may be necessary to suspend the non-statutory 40 working day administrative timetable until the requested information is provided (and, where relevant, the four month statutory deadline for completed mergers – see below).

6.3 In cases that are subject to a statutory deadline – completed mergers and those notified using the statutory merger notice method – the OFT may choose to use a statutory notice under sections 31 or 99 respectively of the Act to request the additional information. If the requested information is not received by the deadline stipulated in the statutory notice, this permits the OFT to extend the relevant statutory timetable for as long as the response to the information requested is overdue, or to reject the merger notice. The OFT is conscious, however, of the need to progress its investigations, particularly in completed merger cases raising the risk of pre-emptive action; it will therefore determine in an individual case whether it is appropriate to extend the statutory deadline or to continue its investigation even in the absence of the requested information.

- 6.4** It is important that merging parties, as soon as possible after receiving a request for information, discuss with the OFT their likely timetable for responding, the extent to which the requested data/information are available, and the form in which they are available. Such discussions may enable the OFT to vary the information request or the stipulated response date (where appropriate).⁷⁶

76 The OFT reserves the right to stop the clock, where appropriate, where information is not provided within the requested deadline.

Discussions with merging parties

- 6.5** The OFT encourages merging parties and their advisers to liaise closely with the case team within the Group during the lifetime of the case. Ideally, this process should start with pre-notification discussions and consideration by the Group of a draft notification before it is formally submitted for review (see paragraphs 4.42 to 4.48 above).
- 6.6** The level of interaction required between merging parties and their advisers and the OFT's case team will depend on the individual circumstances of the case in question. In particular, it will depend on the extent to which the case raises competition concerns and the degree to which the merging parties are willing to engage constructively with the case team to provide evidence to resolve or remedy such concerns (potentially by means of structuring appropriate undertakings in lieu of reference). In cases that raise no material competition issues, it may well be sufficient for the parties to liaise with the case team by email on a periodic basis.
- 6.7** In cases that do raise material issues, the OFT has found that it is often helpful to engage with parties (and/or their legal and economic advisers) at an early stage in the notification process in the form of conference calls and/or meetings. There is no fixed timetable as to when such contacts should occur. Notifying parties may suggest such contacts if they consider they would be useful and the OFT will agree to a meeting where the case team considers it appropriate. Alternatively, such a meeting may be initiated at the invitation of the case team. In complex cases, experience has shown that the OFT may meet with the parties on one or more occasions prior to the formal issues meeting (discussed in paragraph 6.50 below).

- 6.8** In all cases, the OFT commits that, generally in the period between working days 15 and 20 (or 10 and 15 in the case of a statutory merger notice), it will have a ‘state of play’ discussion with the parties, either by conference call or by way of a short meeting. The purpose of this discussion is to give the parties as much information as possible about any competition concerns, including feedback from the OFT’s market test, and whether or not the case team is minded at that point in time to send the parties an issues letter. The case team will also provide an update on the likely timetable for the case going forward.

Third parties

- 6.9** The OFT invites comments on any public merger situation under review from interested third parties by means of an invitation to comment notice published through the Regulatory News Service and on its website at www.offt.gov.uk/advice_and_resources/resource_base/Mergers_home/comment/ It also takes note of any unsolicited comments that are received.
- 6.10** The OFT also targets consultations more specifically by requiring merging parties to provide contact details for their main customers and competitors (see paragraph 5.5 above). Customers’ views tend to be of value in assessing the degree of substitutability between different products or services and therefore in defining the relevant market and in determining the closeness of competition between the parties relative to each other and other non-merging suppliers.⁷⁷ In addition, the OFT seeks to estimate the degree of buyer power exercised by major customers, which may act as a constraint on any market power resulting from the merger.⁷⁸
- 6.11** Competitors, as well as customers, will be asked for their opinions on such matters as the degree of demand- and supply-side substitutability between their products and those of the merged company, entry barriers, market evolution and other relevant issues.
- 6.12** Where third parties express competition concerns about the merger itself, generally, and all else being equal, the OFT will give substantially more weight to concerns of customers than competitors, though it will have regard always to the credibility of the opinions expressed and whether they are substantiated by supporting evidence or are otherwise verifiable.

⁷⁷ In the case of retail markets, customers’ views of the closeness of competition between the merging parties (for example in the context of local stores) may be obtained through survey evidence.

⁷⁸ The OFT may also ask whether customers are aware of any features of the relevant market(s), or activities of the firms acting in them, that they consider restrict or distort competition between firms.

- 6.13** Where adverse third party views raise significant competition issues, the merging parties are informed of the nature of the concerns expressed (but not the actual identity of the persons involved⁷⁹) in sufficient detail to enable them to respond to them whenever the OFT wishes to rely on this evidence in its decision. The time constraints of the OFT process mean that it is not generally appropriate to provide merging parties with non-confidential versions of third party submissions.
- 6.14** The OFT will seek to test any issue material to the outcome of a case directly with the market participant best-placed to supply facts and evidence on that issue:⁸⁰ for example, buyers in relation to buyer power, potential entrants in relation to entry, and rivals in relation to expansion and repositioning of their offer. It will not rely simply on self-serving statements by the merging parties or competitors on the ability, or lack thereof, of rivals to compete with the merged firm. Where it is reasonable to expect a party advancing an argument to substantiate it with internal documentary evidence prepared in the ordinary course of business, the OFT may be more cautious towards the relevant argument in the absence of such evidence. In more extreme cases, where it is implausible that such evidence is unavailable on request, the OFT may dismiss the views of that party as generally lacking credibility.
- 6.15** The OFT may also contact other governmental departments, sectoral regulators, industry associations and consumer bodies for their views on merger cases where appropriate. Sectoral regulators may carry out their own public consultation before providing comments to the OFT. In media mergers involving newspaper publishing and/or commercial radio or television broadcasting, where the case raises prima facie competition concerns, the OFT will ask Ofcom to provide it with a local media assessment in order further to inform the OFT's decisions on the reference test and on the application of any available exceptions to the duty to refer. Drawing on Ofcom's understanding of media markets, the assessment would be likely to include Ofcom's views on:
- the relevant counterfactual to the merger (including the risk of the asset or business in question failing)
 - the scope of relevant product and geographic markets
 - the competitive effects of the merger, and

79 Where useful, the OFT may give the merging parties an indication of the generic position or role of the persons supplying the information where this would not enable them actually to identify the persons involved.

80 UniChem v OFT [2005] CAT 8.

- exceptions to the duty to refer, and in particular Ofcom's views on whether the markets are of insufficient importance (*de minimis*) to warrant reference and whether there are 'relevant customer benefits' – such as higher quality (which, in the context of newspapers, could for example reflect the range and quality of news reporting) or greater choice of products – which might be weighed against an identified substantial lessening of competition.

Although the decision on all of these matters remains one for the OFT, the OFT will take Ofcom's views into account in reaching its conclusions in the same way as it would consider views from other third parties received during the course of its investigation. The OFT will therefore consider Ofcom's local media assessment within the context and timeframe of its normal review processes.

False or misleading information

- 6.16** There are penalties for both notifying parties and third parties supplying false or misleading information to the competition authorities. Section 117 of the Act makes it an offence knowingly or recklessly to supply false or misleading information to the OFT, Ofcom, the Secretary of State or the CC in connection with any of their functions under the mergers part of the Act. It is also an offence to give false or misleading information to any third party knowing that they will then supply it to the OFT, Ofcom, the Secretary of State or the CC. The penalties for breaching this provision are a fine, or a maximum of two years imprisonment, or both.

Confidentiality

- 6.17** It is strict OFT policy to observe confidentiality in all aspects of its operation and the OFT recognises that respecting the confidentiality of commercially sensitive information provided to it is vital to the effective performance of its merger review functions. The OFT will not therefore publicly disclose such information unless required to do so by law.
- 6.18** The classes of information the OFT publishes on its website in relation to mergers includes:
- invitations to comment

- merger decisions under the Act
- case lists
- a public register of undertakings and orders under the Act, and
- merger advice made under the Fair Trading Act 1973.

6.19 The Freedom of Information Act 2000 (the FOIA) was introduced to improve the transparency and accountability of public bodies and gives anyone a general right of access to information held by such bodies, including the OFT.⁸¹ A request for information will be dealt with within 20 working days of receipt.

6.20 There are a number of exemptions from disclosure under the FOIA of potential relevance to a request for information held by the Group, including where disclosure would be prohibited under any statutory enactment including the Act.⁸² Part 9 of the Act, under which information relating to any business of an undertaking may not be disclosed unless the disclosure is permitted under one of the gateways in the Act, therefore continues to apply. Such disclosure is permitted in limited circumstances, for example: with the consent of the person carrying on that business; if such disclosure is for the purpose of facilitating the performance of the OFT's statutory functions; or in pursuance of a European Community obligation. In addition, the OFT may rely on section 31 of the FOIA in withholding information if it considers its disclosure would, or would be likely to, prejudice the exercise by the OFT of its statutory merger functions and there are public interest arguments for maintaining the exemption outweighing the public interest in disclosing the information.

6.21 Other government departments and regulators with sectoral expertise may be given information in confidence so that the OFT can take account of their views on any competition issues and about a possible reference to the CC. When there is a reference, pursuant to section 105 of the Act, the OFT normally makes available to the CC all the information it has in its possession as the CC may reasonably require to enable the CC to carry out its functions (except where that information is confidential under other legislation). This applies to material supplied both by the parties to the merger themselves and by third parties.

81 More information on the FOIA can be found on the OFT's website at www.of.gov.uk/about/freedom/ Requests for information should be sent in writing to: The FOIA co-ordinator, Communications Division, Room 5C/9, Fleetbank House, 2-6 Salisbury Square, London EC4Y 8JX, Fax: 020 7211 8400, Email: foiaenquiries@oft.gov.uk More detailed information on the FOIA is available on the Information Commissioner's website at www.informationcommissioner.gov.uk or by writing to: Information Commissioner's Office, Wycliffe House, Water Lane, Wilmslow, Cheshire, SK9 5AF.

82 Section 44 of the FOIA.

6.22 Further advice on exchanges of confidential information in the context of multi-jurisdictional mergers (similar principles are applicable to exchanges of information with non EC countries) is provided in paragraph 6.66 below.

Initial undertakings and orders

6.23 As there is no requirement to notify mergers in the UK to the OFT, there is similarly no bar to companies completing transactions without clearance from the OFT, or even while in the process of gaining clearance from the OFT. The OFT has no power to prevent parties to an anticipated merger from completing the transaction.

6.24 However, the OFT may, while it is still considering whether to make a reference in a completed merger, accept from the parties undertakings under section 71 of the Act as it considers appropriate to prevent pre-emptive action. Pre-emptive action is defined in the Act as meaning any action that might prejudice the reference or impede the taking of any action that may be justified by the CC's decision if the merger were to be referred (section 71(8) of the Act). In essence, initial undertakings are designed to avoid integration between the two merging parties. As they have suspensive effect on post-merger integration, they are also referred to in practice as 'hold-separate' undertakings. If the parties are unwilling to offer initial undertakings, the OFT may, if the necessary conditions are met, impose an order on the parties under section 72 of the Act to achieve the same objective. All such initial undertakings and orders (including consents thereunder – see paragraph 6.40 below) are published on the OFT's website.⁸³

6.25 The OFT's initial undertakings or orders provide that merging parties 'cease and desist' from integration beyond that which has already taken place at the time of the undertaking being accepted or the order being imposed. However, consent may be given by the OFT (on application by the parties) to undertake certain actions prohibited by the undertakings once they have been accepted or, in the case of enforcement orders, after imposition, where such actions are, in the OFT's view, necessary and do not undermine the purpose of the initial undertakings provided.

⁸³ See www.ofc.gov.uk/advice_and_resources/resource_base/Mergers_home/register/Initial-undertakings/

6.26 Absent compelling risks analogous to those in CC guidance on the use of the hold-separate manager or other more intrusive powers in the context of interim undertakings,⁸⁴ the OFT would not seek to achieve an unwinding of integration that has already occurred, but would instead leave such action to the CC in the event of reference.⁸⁵

6.27 Further details on initial undertakings and orders are given below.

Initial undertakings

Statutory test and timing

6.28 Under section 71 of the Act, initial undertakings may be sought as soon as the OFT has reasonable grounds for suspecting that it is or may be the case that a relevant merger situation has been created.

6.29 Experience has shown that, for initial undertakings to be effective, they should be accepted as soon as possible after completion of the merger in question.⁸⁶ As a matter of practice, the OFT will consider the appropriateness of seeking initial undertakings as soon as it has reasonable grounds for suspecting that a relevant merger situation has been created and where it considers the case warrants initial undertakings being sought (see below). This may be at the time an enquiry letter is sent out or immediately following notification of the transaction. Consideration of initial undertakings routinely takes place in weekly Group meetings and the issue is kept periodically under review during the life of a case. The fact that the OFT has asked for initial undertakings in a particular case does not rule out its eventual clearance of the merger.

Threshold applied by the OFT

6.30 The OFT is likely to seek initial undertakings in respect of a completed merger where there are preliminary indications that the merger raises or is likely to raise competition concerns⁸⁷ and where the circumstances of the case mean that initial undertakings are appropriate to prevent pre-emptive action.⁸⁸ This prima facie decision will take account of any material third party comments that have been received and will draw on the OFT's knowledge of the industry sector in question. A referral under Article 9 of the EC Merger Regulation and/or coherent concerns from UK customers create a strong presumption that initial undertakings or an initial order may be appropriate.

84 See the CC's *Guidance on the use of interim measures pending final determination of merger references*.

85 Section 72(2) of the Act allows the OFT to provide for the carrying on of any activities or the safeguarding of any assets, including by the appointment of a person to conduct or supervise the conduct of any activities.

86 See *Stericycle v Competition Commission* [2006] CAT 21.

87 This part of the test is likely to be satisfied where the OFT has investigated the transaction on its own initiative through the sending of an enquiry letter.

88 As a matter of Group policy, the clearer the case appears for reference, the more expeditious the process for obtaining initial undertakings.

6.31 The threshold the OFT applies to consider whether a case raises substantive concerns such that it may wish to seek initial undertakings is a low one, and lower than that to send an issues letter, because the OFT will not be well placed to judge the severity of the competition concerns at such an early stage in its assessment process. Lengthy consideration of the issue would distract the OFT from expeditious resolution of the case, which may well be a clearance such that any initial undertakings or an order fall away.

6.32 In addition to considering whether there are preliminary indications that the merger raises or is likely to raise competition concerns, the OFT will consider the risk of pre-emptive action and the issues of urgency and proportionality. Taking as its starting point (i) relevant theories of harm to competition, (ii) the state of current integration and the (iii) parties' stated integration plans, the OFT is likely to evaluate the following:

- risk of loss of critical know-how of key management and staff of target business through staff departures/redundancies
- risk that key physical assets will be sold or rendered inoperable
- risk of flow of competitively-sensitive information (eg pricing, expansion, research and development, and innovation plans) that cannot be 'reversed' in a remedial context⁸⁹
- importance to the target's independent competitiveness of key customer and/or supplier relationships and goodwill, including brand reputation, and
- any other relevant facts considering likely theories of harm and arguments advanced by the parties or third parties.

Proportionality and customisation

6.33 The OFT attaches importance to proportionality and a desire not to burden benign transactions with delay and cost, and so does not seek undertakings in cases that do not raise concerns or where there is clearly no material risk of pre-emptive action.⁹⁰ In cases (alleged to) raise competition issues, however, the OFT recognises that completed mergers that harm competition pose potentially irreparable long-run harm to consumers.⁹¹

89 See Co-operative Group (CWS) Limited v OFT [2007] CAT 24 in relation to the treatment of firewalls in this context.

90 At the time of publication of this guidance, the OFT tended to seek initial undertakings in approximately one third of completed merger cases it investigated.

91 This explains why the Act specifically introduced an initial undertakings power for the OFT that it lacked under the Fair Trading Act 1973.

- 6.34** Accordingly, in such cases the inherent short-run cost and disruption to parties of initial undertakings will generally be given little, if any, weight in balancing the long-run risk of consumer harm for two reasons. First, this cost was avoidable as it was open to parties to complete a transaction without commencing integration, or indeed to seek to manage the merger control risk upfront by seeking pre-merger clearance. Second, any cost and inconvenience imposed by the OFT is short-lived, being generally limited in time to the standard 40 working day duration of its investigation. If the merger is cleared or undertakings in lieu are accepted the burden is lifted; if referred, the parties have a fresh hearing on the issue of interim undertakings with the CC.
- 6.35** In this respect, a distinction should be drawn between parties' rights to make unconditional bids to acquire share capital or assets, especially useful in auction settings, on the one hand, with the actual 'scrambling of eggs' involved in post-merger integration after closing, on the other. The obtaining of initial undertakings bites only on the latter, whilst leaving parties free to complete mergers if they are prepared to assume regulatory risk.
- 6.36** However, proportionality will go to the issue of the scope of the undertakings, as the OFT will balance its risk assessment against the commercial context and efficiencies of the transaction and the scope of relevant theories of harm. For example, for reasons of proportionality, in a multi-national transaction, any undertaking would presumptively apply only to UK assets and information flow; similarly, in a merger raising only sub-national issues, and where the principal or only scope for remedies is likely to be divestitures of stand-alone local or regional businesses in the UK, the OFT may permit some, or greater, degree of integration at head office or back office level, but would be unlikely to do so if there were possible national competition issues.

Procedure

- 6.37** To reduce the burden on the parties, and to speed up implementation of initial undertakings, the OFT has developed a standard text for initial undertakings (which largely mirrors that of the CC for ease of adoption). The template used by the OFT when seeking initial undertakings for a completed merger is available on the OFT's website at www.of.gov.uk/shared_of/mergers/Initialundertakingstemplate.doc This includes a provision stipulating regular updates on compliance to the OFT by designated individuals on behalf of the notifying parties.

- 6.38** When making a request for initial undertakings, the OFT will provide the parties with a short period of time (typically two working days) in which to make any representations on the suitability of the proposed undertakings in the circumstances of the case.
- 6.39** The OFT will consider carefully any arguments presented in response. However, the OFT will not engage in a lengthy process of exchanging comments on individual undertakings in the manner of a private commercial negotiation. Given that a generic template will, in some circumstances, lead to a disproportionate regulatory burden, the OFT will provide the required flexibility not through negotiating undertakings at length up-front, but in considering subsequent waiver or consent requests that will exempt certain specified business areas or conduct from the hold-separate obligation if justified. Such consents may be required, for example, in order to ensure the ongoing financial viability or proper management of the acquired company.
- 6.40** If agreed, such consent letters will be published by the OFT on its website alongside the initial undertakings to which they relate. Prior to publishing such a consent letter, the OFT will provide the parties seeking consent with a reasonable opportunity (at least one working day) to revert with any requests for business secrets to be redacted from the published version of the document.
- 6.41** The OFT case team will ensure that any such consents given by the OFT to the merging parties under the initial undertakings will be provided to the CC if the transaction is referred.⁹³

Initial enforcement orders

- 6.42** To the extent that the parties demonstrate that they are not genuinely willing to provide initial undertakings within a short timeframe of being requested, the OFT is likely in appropriate cases to move swiftly to the imposition of an initial enforcement order under section 72 of the Act.
- 6.43** The OFT has the power to impose initial enforcement orders to prevent pre-emptive action when it has reasonable grounds for suspecting that it is or may be the case that a relevant merger situation has been created and that pre-emptive action is in progress or in contemplation.

⁹² The CC will normally adopt initial undertakings accepted by the OFT under section 71 of the Act if the transaction is referred (section 80(3) of the Act).

- 6.44** In practice, the OFT will generally consider imposing an initial enforcement order only where it has already given merging parties a reasonable opportunity to provide initial undertakings, but they have not been forthcoming. The additional legal threshold under the Act for the OFT to impose an order – that it has reasonable grounds for suspecting that it is or may be the case that pre-emptive action is in progress or in contemplation – is a low one. The OFT considers that an unwillingness by the parties to provide initial undertakings (absent a reasonable explanation for such a refusal) may itself be supportive evidence of the fact that pre-emptive action is in progress or contemplation.
- 6.45** Before imposing an initial enforcement order on the merging parties under section 72 of the Act, the OFT will provide the merging parties with a reasonable opportunity (typically one working day) to comment on its proposed course of action and to make representations as to why the making of an order would not be appropriate in the circumstances of the case.

The decision making process

- 6.46** In cases that raise no serious competition issues, the decision to clear the merger is made within the Group. The Group, acting on behalf of the OFT, prepares a clearance decision paper and circulates it to an OFT review group, which includes the Chairman, the Chief Executive, the Executive Director for Markets and Projects, the Head of the Policy Unit, OFT General Counsel, OFT Chief Economist or a deputy, the Group Senior Director and Group Director, representatives of the Group and of the OFT Market Groupings Unit relevant to the sector in question if appropriate.
- 6.47** Members of this review group that disagree with the decision or think that the case raises issues that require further discussion can request that a case review meeting (CRM) be held. If there are no calls for a CRM, the decision is finalised, relayed to the parties or their advisers and announced publicly. The text of the decision is subsequently published on the OFT's website (see paragraph 6.64 below).
- 6.48** In cases that raise more complex or material competition issues, a different process is followed involving an issues meeting with the

parties and then internal consideration of the case by the OFT at CRM. In many cases, merging parties will be aware from the outset that the case raises material concerns that will require a more in-depth consideration by the OFT. In a number of cases, merging parties have proactively identified the areas giving rise to concerns, thereby enabling the case team to consider (and potentially assist the merging parties to resolve) those areas early on in the investigation process.

6.49 As noted above (see paragraph 6.8 above), the OFT will, generally between working days 15 and 20 (or 10 and 15 in the case of a statutory merger notice), have a ‘state of play’ discussion with the parties, either by conference call or (in relatively rare cases) by way of a short meeting. This discussion will provide the merging parties with as much information as possible about any competition concerns, including feedback from the market investigation and whether or not the Group is minded to send the parties an issues letter.

6.50 Once a merger has definitely been identified as warranting consideration at CRM (ie a CRM case), the parties are advised as soon as possible and will be invited to attend an issues meeting with the Group. To help the parties prepare for the issues meeting, the case officer sends an issues letter to the parties.

- The issues letter sets out the core arguments in favour of a reference in the case so that parties have an opportunity to respond to the outlined concerns. The OFT seeks wherever possible to limit the content of the issues letter to include only theories of harm that are genuinely of concern or of potential concern. Where appropriate, it may give guidance in the issues letter, sometimes by a form of ‘grading’ or ‘ranking’, of the extent of its concern regarding different theories of harm to try to enable respondents to focus on those issues that appear most likely to lead to the test for reference being met.
- Not all the concerns in an issues letter necessarily originate from the OFT, nor have been fully explored if, for example, they are raised by third parties at a late stage in the investigation. In these circumstances, the fact that the issues letter is sent does not necessarily mean that the case team fully shares the concerns in the issues letter at that stage.⁹³

93 Case teams who believe a case should ultimately be cleared may nonetheless send an issues letter in certain circumstances: (i) to increase the robustness of the case for likely clearance with the parties, allowing review of the case for and against reference by the CRM college (see paragraph 6.57 below in this respect); and (ii) so as not to prejudice the ability of the senior OFT decision-maker to decide the case differently.

- The issues letter is therefore not a provisional decision or a statement of objections. Rather, the issues letter sets out hypotheses which the OFT is still evaluating in the light of the evidence put to it by the parties and gathered from third parties.
- The issues letter does not discuss in detail the arguments in favour of clearance.

- 6.51** Once an issues letter is sent, the OFT will inevitably follow the remainder of the CRM process, even if new evidence received thereafter would suggest that the case no longer requires a CRM. This is to provide some degree of certainty (for both the OFT and the merging parties) about the structure and timing of the decision making progress in these cases.
- 6.52** The OFT will provide the merging parties with an interval of at least two working days between receipt of the issues letter and the date of the issues meeting to allow parties time to prepare. Although this is a relatively short time period, the description of the competition concerns provided by the case team in the state of play discussion should ensure that, when an issues letter arrives, it contains few, if any, surprises. This in turn should reduce the practical burden on the parties of having to prepare for an issues meeting after receipt of the issues letter.
- 6.53** Parties to a merger may either respond to the issues letter in writing, or orally at an issues meeting, or both. The OFT has found that it can be helpful for parties, where possible, to provide a written response to the issues letter in advance of the issues meeting and then, if necessary, to follow-on with a short supplementary paper addressing any further points in the light of the discussion at the issues meeting. However, the choice of whether to provide a written response before or after the issues meeting (or both) is entirely up to the parties.
- 6.54** It is not the OFT's practice to provide third parties with the opportunity to comment on the issues letter in light of the time and confidentiality constraints under which its investigations are carried out. Third parties will not normally be informed as to whether an issues letter has been sent in a particular case (and therefore whether a CRM will be required). However, to the extent that the OFT wishes to rely in its decision on key facts relating to a third party that have been not previously been confirmed with the third party in question, it will verify such facts with third parties around this time (see paragraph 6.14 above).

- 6.55** Issues meetings will generally be chaired by a Deputy Director or the Director of the Group. In addition to the case team, they will often also involve a legal officer and a senior economist within the Group. To enhance the level of scrutiny to which the case team's recommendations are subjected, an official outside the Group is charged specifically with acting as 'devil's advocate' to comment critically on the case team's recommended outcome (whether that be for or against reference), and will therefore also generally attend the issues meeting.
- 6.56** From the parties' side, it is important that there is at least one representative from the merging parties at the issues meeting who is able to speak authoritatively on the business areas affected by the merger, in addition to representatives from legal or regulatory affairs. The OFT will often provide guidance to the parties on which class of representatives it considers it would be most useful to hear from directly at the issues meeting, although the choice of attendees ultimately rests with the parties. Parties may wish to provide an agenda or presentation for the issues meeting, particularly where they have not yet responded in writing to the issues letter.
- 6.57** Following the issues meeting, the Group's internal economic analysis, the issues letter and any written response to the issues letter from the parties are circulated to the members of the review group in advance of a CRM. The CRM is usually chaired by the Director of Mergers, and will be attended by the OFT staff who attended the issues meeting, potentially also with a representative from the OFT Chief Economist's Office, and colleagues from the relevant OFT Market Group if appropriate. The 'devil's advocate' will always be present at the CRM.
- 6.58** Following the CRM, there is a separate decision meeting, chaired by the decision maker, generally the Chief Executive or the Senior Director of Mergers, or in some cases another official at the grade of Senior Director (SCS Grade 3) or above. The decision meeting is normally attended by those officials who attended the CRM and will always include the chair of the CRM and the 'devil's advocate'. The decision maker will not have attended the case review meeting.
- 6.59** At the decision meeting, the decision maker hears a report on the debate at the CRM, including its overall recommendation, and is then able to determine whether he or she agrees with the recommendations. In a minority of cases there will not be a consensus

of opinion emerging from the CRM as to its recommendations for clearance or reference (or, exceptionally, even as to the reasoning for such a recommendation). In such cases, the non-consensus position will be relayed to that effect, and (in the absence of a CRM majority view) the 'devil's advocate' argues the parties' case.

- 6.60** In a minority of cases, the decision maker may decide to adjourn the decision meeting where he or she wishes to reflect on the case further before reaching a final view, evaluate the robustness of the provisional decision by way of a full draft decision, or have the case team verify a particular factual or evidential point.
- 6.61** The decision maker is required to decide whether or not the test for reference is met without being informed whether the parties have offered undertakings in lieu of reference. In cases where the decision maker concludes that the test for reference is met, ie that it is or may be the case that the merger has resulted or may be expected to result in a substantial lessening of competition, the decision maker will then consider whether any of the available exceptions to the duty to refer should be applied (most commonly the '*de minimis*' exception). Only if the OFT decision maker decides that he or she intends to refer the merger will he or she then be informed as to whether the parties have offered undertakings in lieu of reference. If parties have offered undertakings in lieu of reference, the decision maker will consider whether they are sufficient to warrant suspending the duty to refer (see paragraphs 8.13 to 8.17 below for the procedure for consideration of undertakings in lieu of reference).
- 6.62** Following the decision meeting, the case officer then prepares a draft decision in accordance with the decision maker's reasoning offered verbally at the decision meeting. This process generally takes one to two weeks. The provisional decision becomes final only when the prepared draft document is signed by the decision-maker. On the day that the decision is finalised and signed, the outcome is communicated to the parties or their advisers and then announced publicly one hour thereafter. The OFT will normally issue a press release in reference and undertakings in lieu cases, and may exceptionally issue a press release in a clearance case where the facts of the case warrant it. The text of the decision is subsequently published on the OFT's website, subject to excision of business secrets (see paragraph 6.64 below).

Publication of decisions

6.63 Section 107 of the Act requires the OFT to publish all of its decisions on whether or not to refer in merger cases. This includes decisions that a transaction is not a relevant merger situation (ie a ‘found-not-to-qualify’ or ‘FNTQ’ case), clearance decisions (including ‘*de minimis*’ cases), acceptances of undertakings in lieu of a reference and references to the CC.

6.64 Publication is generally a two step process.

- The first step is the announcement of the nature of the OFT’s decision, done through the Regulatory News Service and placed on the OFT website, usually at 11am or 3pm. The OFT has a system for advanced warning for merging parties. Although the case team will seek after the decision meeting to keep the merging parties informed of the likely date for announcement of the decision, notifying parties or their advisers will be contacted one hour before the actual public announcement of the decision to advise them of the precise timing and nature of the decision. In those cases where a press release is issued, this will normally be sent to the parties at the same time. In every case, an email or fax will be sent to the parties or their advisers that lays out the terms on which this price sensitive information is being provided, to which it is a condition that the parties should provide agreement in advance. Should there be any difficulty with handling of price-sensitive information in a particular case, the OFT would consider, if necessary, adjusting its procedure going forward and reverting to a situation of giving the notifying parties just five minutes’ notice of the fact of an announcement instead of an hour.
- The second step, some time later, is the publication of the text of the decision on the OFT’s website, which will be cross referenced in the OFT’s Weekly Gazette and announced on the Regulatory News Service. Following announcement of the decision, but before it is published, the text of the decision will be circulated to the parties or their advisers to enable them to request the excision of business secrets from the text if necessary to protect confidentiality. The OFT will be mindful of the need to respect the confidentiality of

commercially sensitive information provided to it (by the merging parties and third parties). At the same time, it is required by section 107 of the Act to publish its decisions and it will try to ensure that evidence that is key to the reasoning and outcome of its decision is included within the public version of the decision. The OFT will therefore ask that, when parties make requests on the excision of business secrets from the text, they justify each of those requests and do not make blanket claims that particular classes of information are confidential.⁹⁴

- 6.65** In drafting a decision, the OFT will set out the reasoning on which it has come to its conclusion. This allows interested parties to know the justification for the measure so as to enable them to protect their rights, to know the outcome and to enable them to assess whether they have any ground for challenging an adverse decision.

⁹⁴ In relation to market share data, the OFT will normally require that such information is published but will accept that the data are given as falling within a range rather than a precise number.

The European Competition Authorities Network

- 6.66** The European Competition Authorities (ECA), a network of competition agencies, was formed in 2001 from the competition authorities in the European Economic Area (EEA) (the Member States of the European Community, the Commission, the EFTA States and the EFTA Surveillance Authority). Further competition authorities have joined the ECA as the countries became members of the European Community and others may join. The ECA facilitates cooperation among competition authorities on a wide range of issues.
- 6.67** To facilitate the consideration of mergers that are subject to investigation in more than one ECA country (multi-jurisdictional mergers), an ECA Network was set up. It has been agreed that when an ECA authority is informed by the parties to a merger that they have also notified or will be notifying the merger to other authorities within the ECA, the relevant official within that authority will, as soon as possible, send by email an ECA notice to the relevant officials in the other ECA authorities informing them of the fact of notification, and seeking the names of the relevant officials in other ECA authorities to whom the merger has been notified.

95 This may include the exchange of information with competition authorities outside the ECA Network, such as the US Federal Trade Commission and Department of Justice.

96 The gateway for permitted disclosure of specified information to overseas public authorities under section 243 of the Act does not apply to information that comes to the OFT in connection with a merger investigation (section 243(3)(d) of the Act).

6.68 The relevant officials of the notified ECA authorities will then make direct contact with the appropriate case officer and exchange views on the case without exchanging confidential information (unless national legislation or a waiver from the parties makes this possible). The relevant officials will keep each other informed of the development of the case as appropriate.

6.69 Where national legislation prevents the exchange of confidential information and it seems likely that:

- the analysis will demonstrate a competition problem worthy of further investigation or, potentially, of remedy, and
- an exchange of confidential information will benefit the analysis of the case or make it easier to identify an appropriate remedy.

The authorities may seek permission from the parties to exchange confidential information.⁹⁵ Without such permission, there will be no exchange of such information.⁹⁶

7 Fees

- 7.1** Subject to some limited exceptions, any merger that qualifies as a relevant merger situation (including on the 'may be the case' standard) and is investigated by the OFT is subject to a fee (collected by the OFT on behalf of HM Treasury) irrespective of whether a reference is made.⁹⁷ The main exception is where the interest acquired or being acquired is less than a controlling interest (see chapter 3 above) and a merger notice has not been submitted in relation to the acquisition.⁹⁸ In addition, a fee is not payable when the enterprise is a small or medium sized enterprise (see below).
- 7.2** For merger notified using a statutory merger notice, payment must be sent with the completed notice. The period for considering the notice does not begin until the first working day after the completed form and the correct fee has been received. The fee is payable by the person submitting the statutory merger notice.
- 7.3** For other mergers (including anticipated mergers that are not notified by means of a statutory merger notice) that involve the acquisition of a controlling interest, the fee is payable by the person or group of persons acquiring such an interest and becomes payable on the publication by the OFT of either a reference decision or any decision not to make a reference. No fee is payable if the OFT finds that the case does not qualify as a relevant merger situation. For cases resolved through undertakings in lieu, the fee becomes payable when the OFT loses its duty to refer as a result of its formal acceptance of undertakings in lieu. In the case of public interest cases decided by the Secretary of State, the fee becomes payable to the OFT when the Secretary of State publishes a reference decision under section 45 of the Act or publishes any decision not to make such a reference. In all cases, an invoice will be issued by the OFT when the fee becomes payable. Payment must be made within 30 days of the date of the invoice.
- 7.4** Given that a fee is payable whenever the OFT reaches a decision whether or not to refer in respect of a relevant merger situation, a fee will be payable in cases where the OFT decides to investigate the merger on its own initiative. The OFT will generally proceed to publish a decision, and therefore require a fee in relevant merger situations, in all cases in which it has sent a formal enquiry letter to the parties (see paragraph 4.15 above).

97 Full details in respect of the payment of fees are, pursuant to section 121 of the Act, set out in the Enterprise Act 2002 (Merger Fees and Determination of Turnover) Order 2003 SI 2003/1370.

98 It should be noted, however, that multiple parties may be treated as one person for the purposes of determining whether fees are payable, potentially as a result of the application of the 'associated persons' provision, in which case they are jointly and severally liable for the fee under Article 6(4) of the Enterprise Act 2002 (Merger Fees and Determination of Turnover) Order 2003 SI 2003/1370.

7.5 Fees may either be paid by banker's draft or cheque, payable to the Office of Fair Trading and crossed 'AC Payee only', or, preferably, by BACS or Clearing House Automated Payments Systems (CHAPS). The fee must be paid in sterling. If payment is made by an electronic transfer, the amount of payment received must be net of any service, transfer or wiring fees charged by any bank or financial institution.

7.6 Any cheque sent as payment should be accompanied by the invoice or the statutory merger notice. Payment by BACS or CHAPS should include the reference number, the acquirer's name, the OFT's file reference and invoice number, if applicable, using the following information:

By BACS

Bank of England

Account number 11673000 – Office of Fair Trading

Sort Code Number 10 14 99

By CHAPS

Natwest Account Number 11673 – Office of Fair Trading

Sort Code Number 16 53 60

Swiss No. NWBKGB2L

7.7 A refund may be made for a merger notified using a statutory merger notice (that is, where the fee is paid upon notification – see paragraph 7.2 above) which is subsequently referred to the Commission under Article 22 of the EC Merger Regulation. When such a merger is found to fall within the scope of the EC Merger Regulation, or is found more generally not to qualify for investigation under the Act, a refund must be made. The merger fee cannot, however, be refunded if the statutory merger notice is simply withdrawn. However, in cases where the parties withdraw a statutory merger notice and re-notify the same transaction using an informal submission, no extra fee will be payable.

7.8 Fees vary according to the type and size of the merger. Details of the current fee scales are available from the Group and are set out in OFT – *Mergers fee information* (February 2006).

- 7.9** Small and medium sized enterprises (as defined by sections 382 and 465 of the Companies Act 2006⁹⁹) are exempt from paying the above fees.
- 7.10** Fees are payable on the making of a merger reference under the Water Industry Act 1991 (see chapter 10). In such cases, the level of the fee is determined depending on the value of the turnover of the water enterprise being acquired in England and Wales.¹⁰⁰

99 At the time of writing, small enterprises are those satisfying two or more of the following criteria: (i) turnover of not more than £6.5 million; (ii) balance sheet total of not more than £3.26 million; (iii) number of employees not more than 50. Medium enterprises are those satisfying two or more of the following criteria: (i) turnover of not more than £25.9 million; balance sheet total of not more than £12.9 million; (iii) number of employees of not more than 250. Full details are set out in sections 382 and 465 of the Companies Act 2006.

100 The Enterprise Act 2002 (Merger Fees and Determination of Turnover) Order 2004 SI 2004/3204, amending The Enterprise Act 2002 (Mergers Fees and Determination of Turnover) Order 2003 SI 2003/1370.

8 Remedies

Undertakings in lieu of reference

- 8.1** In the OFT’s experience under the Act to date, problematic mergers engaging the OFT’s duty to refer can be thought of as having fallen into two broad categories. The first category comprises ‘binary’ cases where all, or substantially all, of the transaction is responsible for the competition concerns, which do not easily lend themselves to acceptable undertakings in lieu of reference.
- 8.2** The second category involves cases where, first, the problematic overlaps represent a more minor proportion of the transaction and, second, those overlaps involve asset packages – such as stand-alone businesses in separate local markets – that are severable from the remainder of the transaction without materially affecting the overall commercial rationale for the merger. The latter cases have almost invariably led to ‘structural’ undertakings in lieu to divest relevant assets to a suitable third party purchaser approved by the OFT.
- 8.3** Under the Act, the OFT (or the Secretary of State in public interest cases) may accept binding undertakings from a merged business as an alternative to making a reference to the CC.
- 8.4** Undertakings in lieu provisions may be used only where the OFT (or the Secretary of State in public interest cases) has concluded that the merger – whether anticipated or completed – should be referred to the CC. Any OFT undertakings must be for the purpose of remedying, mitigating or preventing the substantial lessening of competition concerned or any adverse effects identified.
- 8.5** In order to accept undertakings in lieu of reference under section 73 of the Act, the OFT must be confident that the competition concerns identified will be resolved by means of the undertakings offered without the need for further investigation. Undertakings in lieu of reference are therefore appropriate only where the competition concerns raised by the merger and the remedies proposed to address them are clear cut, and those remedies are capable of ready implementation.

- 8.6** In cases in which there is doubt over the precise identification of the substantial lessening of competition or in which the effectiveness or proportionality of the proposed undertakings in lieu may be questioned, the OFT considers it unlikely that the 'clear cut' standard referred to in paragraph 8.5 above would be met. In these circumstances, acceptance of undertakings in lieu would not be appropriate.
- 8.7** More guidance on structural and behavioural undertakings in lieu and their substantive consideration can be found in *Mergers – substantive assessment guidance* (OFT516).¹⁰¹

Procedure for submission of undertakings in lieu

- 8.8** The Act gives the OFT a discretion to accept undertakings in lieu of reference from such of the parties concerned as it considers appropriate. Unlike the CC, the OFT has no power to impose remedial action on merging parties.¹⁰² It is therefore for the parties to offer remedies sufficient to address the competition concerns, although the Group will seek to provide any guidance it can to the parties, and be as transparent as possible as regards its thinking, during the course of the investigation in order to facilitate this process and maximise the prospects of successful undertakings in lieu being offered.
- 8.9** An acquiring company may always take the initiative to propose suitable undertakings in lieu in pre-notification discussions, upon formal submission of the notification to the OFT or during the initial stages of the investigation if it considers that they may be appropriate to meet any competition concerns that it foresees.¹⁰³ Indeed, even where proposed undertakings in lieu are not actually communicated to the Group, the OFT strongly recommends that, in suitable cases, notifying parties and their legal advisers themselves consider undertakings in lieu during pre-notification and in the early days of the OFT's assessment. This ensures that, at the point when the undertakings in lieu are actually proposed, discussions between the OFT and the parties may proceed rapidly, thereby maximising the chances of acceptance before the deadline for reference is reached.

101 The OFT intends to publish separate guidance on its exceptions to the duty to refer and undertakings in lieu.

102 The OFT does have power under section 75 of the Act to make an order where an undertaking in lieu has not been, is not being or will not be fulfilled, or where the undertaking in lieu was given following the provision of false or misleading information to the OFT by the party giving the undertaking.

103 Such discussions with the case team will not impact on the prospect that the OFT decision maker ultimately determines that the test for reference is not met; nor will they prejudice the parties' right ultimately to decide not to offer any undertakings in lieu.

- 8.10** In terms of deadline, the period immediately after the issues meeting but before the CRM provides the final opportunity for parties to offer written undertakings in lieu. In many cases, parties will indicate to the Group what undertakings in lieu they are prepared to offer prior to the issues meeting. In other cases, at the end of the issues meeting, the OFT official chairing the meeting will ask the merging parties whether they wish to offer undertakings in lieu in order to avoid a reference. They may wish to respond orally in the issues meeting, or immediately after the issues meeting in writing, although engagement with the case team at the issues meeting is likely to help reduce the risk of the undertaking in lieu falling short. In any event, all offers of undertakings in lieu should be made to the OFT prior to the CRM, which is likely to be followed soon, or immediately, after by the formal decision meeting.
- 8.11** In making an offer of undertakings in lieu, parties should be clear in identifying what it is they are offering (or not offering). In the case of structural divestments, parties should identify precisely what business or businesses they are offering to sell.
- An offer merely to ‘remedy the SLC’, without specifying how this will be achieved, will be considered insufficiently clear-cut to enable the OFT to suspend its duty to refer.
 - An offer to remedy the SLC through divestment of one of the overlapping businesses should make it clear whether the parties are prepared to divest the overlap assets of the target, acquirer or either.
 - Where the parties name only one business, the OFT will infer from this that they would not be prepared to sell the other overlapping business. In making this decision, parties should be aware that, in certain cases, the OFT may consider that divestment of one of the overlapping businesses, or of one particular business, may not be sufficient to remove the competition concerns given the need for the divestment to be a viable business and to be capable of attracting a suitable purchaser.
- 8.12** The Group case team (but not the OFT decision maker) will assist merging parties in understanding the function of undertakings in lieu. They will also, wherever possible, provide guidance to parties on how remedies might operate given the competition concerns provisionally identified in the case in question. This is likely to be objectively obvious in many cases and to most experienced users. In other cases, the

case team may give their view as to what undertakings in lieu might be acceptable in the event that the test for reference is met and any risks the team foresee up-front. However, the case team is not able formally to agree with the parties about whether a particular package of undertakings would or would not be sufficient. This is because the final decisions on whether, first, the duty to refer arises and, second, whether to accept undertakings in lieu are not to be pre-judged and remain with the decision maker once all the evidence in the case has been evaluated. In addition, the OFT considers that it is important for the case team to focus more heavily on the assessment of the competitive effects of the transaction during the investigation process.

Procedure for consideration of undertakings in lieu

8.13 Section 73(1) of the Act makes it clear that the OFT's discretion to accept undertakings in lieu in a given case arises only when it has found that it is under a duty to refer. The OFT places great importance on making the assessment of its statutory duty independent of the question of available remedies because there is no legal basis to consider issues relating to undertakings as relevant when deciding whether the OFT is under a duty to refer. This would amount to taking an irrelevant consideration into account, or in more colloquial terms, to 'reverse-engineering' the OFT's substantive analysis to accept a remedy without having properly considered whether the public policy justification for doing so – a realistic prospect of a substantial lessening of competition – applies in the case at hand.

8.14 In practical terms, this principle is upheld within the context of the OFT's decision-making procedure through the fact that the decision-maker is not informed about whether or not the parties have offered undertakings in lieu of reference until after he or she has reached a decision as to whether the duty to refer has arisen. For this reason, parties are requested to detail any undertakings in lieu offer in a separate document to any response to the issues letter (as the latter will be provided to the decision maker for his or her consideration prior to the decision meeting). The sequencing for the OFT's decision meeting therefore runs as follows.

- Consideration of whether the test for reference is met, that is whether it is or may be the case that the transaction has resulted or may be expected to result in a substantial lessening of competition.

- If the test for reference is met, consideration of whether the OFT considers it appropriate to exercise one of its discretionary exceptions to the duty to refer under section 22 or section 33 of the Act, that is the exception for markets of insufficient importance (*'de minimis'*) or the customer benefits exception.¹⁰⁴
- Only if there is a duty to refer, and the OFT decides not to exercise any of the available exceptions to the duty to refer, will the decision maker then consider whether to accept undertakings in lieu of reference to the extent they have been offered by the parties.

8.15 The OFT is given the discretion to accept undertakings in lieu for the purpose of remedying, mitigating or preventing the substantial lessening of competition or any resultant adverse effect from the merger. In exercising this discretion, it will have regard to the need for the remedy to be effective in relation to the harm identified. Where a range of undertakings are offered, the OFT (that is, the decision maker) will therefore take only those that are necessary to remedy the competition concerns that have been found.

8.16 To the extent that the parties consider that, based on the issues letter, there is a spectrum of competition concerns and corresponding remedy options, for example, in the context of fascia reduction in local market cases, starting with '2 to 1' cases, followed by '3 to 2' cases, followed by '4 to 3' cases, it is open to the parties to offer a sequence of different remedy options. For example, option one might offer to divest the target overlapping assets in '2 to 1' cases, failing which option two would offer to divest also in '3 to 2' cases, and so on.¹⁰⁵

8.17 The manner in which the parties choose to offer undertakings in lieu, and the fact that they ultimately decide to offer a sequential range of remedy offers, does not prevent the parties from engaging previously with the case team on what undertakings in lieu might be appropriate in a given case (see paragraph 8.9 above).

¹⁰⁴ In the case of anticipated mergers, the OFT may decide that the arrangements concerned are insufficiently far advanced or insufficiently likely to proceed to justify the making of a reference.

¹⁰⁵ Such sequential offers may be made by way of letter or in sequential envelopes if the parties prefer. Where offers of undertakings in lieu are made by way of a procedure involving sequential envelopes, it may be that the OFT is able to return certain envelopes unopened to the parties where the OFT is satisfied that one of the parties' offers is sufficient to remedy the substantial lessening of competition concerned. The OFT considers the use of mechanisms such as sealed envelopes to be unnecessary, but it recognises that merging parties and their legal advisers may consider such procedures, and the transparency they bring, as providing comfort.

OFT discretion in 'near miss' undertakings in lieu cases

- 8.18** The OFT requires that parties submit any undertakings in lieu they wish to have considered before the case is considered at CRM. As a starting proposition and general principle, and subject to paragraphs 8.19 to 8.23 below, the OFT will therefore not consider any undertakings in lieu that are submitted after the CRM.
- 8.19** The OFT is mindful, however, of the significant public policy benefits (to consumers, the parties and the public purse) that are achieved through the undertakings in lieu process. It will therefore be slow to reject undertakings in lieu offered by the parties for purely technical reasons, or because they might be read as falling just short of a package that the OFT considers would otherwise be sufficient to remedy the concerns identified. The OFT therefore reserves the right to revert to the parties¹⁰⁶ to clarify their undertakings in lieu offer in exceptional circumstances that might best be described as 'near miss' cases. In these circumstances, the parties would be offered a short second window of opportunity (typically not more than one working day) to reconsider (and potentially clarify) their original offer of undertakings in lieu. In practice, this communication is likely to take the form of a short telephone call between a senior member of the Group and the nominated individual representing the merging party that had offered undertakings in lieu, which would be likely to be followed up in writing. The OFT might choose to exercise this discretion at any point in the process after the parties had offered undertakings in lieu.
- 8.20** The parties will be made aware of the reason why their existing undertakings in lieu offer would be likely to fall 'just short' of acceptable clear-cut undertakings in lieu. It is then up to the parties whether they wish to clarify or revise their undertakings in lieu offer in response to this explanation.
- 8.21** The OFT will consider exercising this discretion to revert to merging parties only in a narrow range of 'near miss' circumstances where the following eligibility conditions are met:
- The OFT will exercise its discretion only where the parties have already made what is clearly a 'good faith' and credible offer of

¹⁰⁶ In practice, this is most likely to mean to their legal advisers.

undertakings to remedy the identified competition concerns in advance of the CRM. In general, offers of behavioural undertakings that purport to regulate parameters of competition (for example, price, quantity, quality) are unlikely – save in the most exceptional circumstances – to be considered to be ‘near miss’ circumstances as an offer of a behavioural undertaking of this type would not generally (absent particular facts) be considered to be a credible clear-cut remedy.

- The OFT would be unlikely to regard as a ‘near-miss’ a situation where the parties have chosen not to offer undertakings in respect of a certain level of concentration or certain overlapping locations. For example, where the issues letter identified concerns in local areas involving fascia reduction in ‘2 to 1’ and ‘3 to 2’ overlaps (such that the parties were put on notice that both sets of areas were potentially of concern), but where the parties offered undertakings only in relation to the former class of cases, the OFT would not revert subsequently in the event that the decision meeting established that the test for reference was met in ‘3 to 2’ cases also. Equally, where a specific geographic locality had been identified as raising concerns in the issues letter, but the parties chose not to offer undertakings in lieu in respect of that locality, the OFT would be unlikely to revert in the event that the decision meeting established that the test for reference was met in that locality.
- Where relevant, the OFT will agree to provide a short period of additional time for submission of revised undertakings in lieu (likely to be one working day) only where the parties agree to an extension of the OFT’s administrative timetable (and statutory deadline, where relevant) for this purpose.
- Comments or information given by the OFT when it reverts to the parties must be accepted as being not binding on the ultimate decision maker. Nonetheless, the information will be provided on a strictly confidential basis and any company benefiting from this option will be requested not to reveal this fact.¹⁰⁷

8.22 In all cases, the existence or otherwise of a ‘near miss’ situation will be narrowly construed at the discretion of the OFT. It will not be open to the parties to request or require a further opportunity to submit

107 The OFT does not wish to create expectations about the outcome of its decision by allowing the fact that it has reverted to the parties in a ‘near-miss’ undertakings in lieu case to become public knowledge. The OFT will explain to the parties, or their advisers, the terms on which the information is being provided, for which it will be a condition that agreement must be given in advance. This may include a requirement for the parties and their advisers to set up and maintain internal controls, including limiting access of the confidential information on a ‘need to know’ basis. In the event of a leak of information, the OFT would consider taking appropriate action and, if necessary, suspending the procedure going forward.

undertakings in lieu after the CRM. It will therefore always be in the best interests of the parties to submit their best offer of undertakings in lieu at or immediately after the issues meeting.

- 8.23** In the event of any abuse of this 'near-miss' process, the OFT is prepared to suspend or withdraw this option, either on an individual basis for the parties and/or legal advisers concerned, or more widely.

Procedure for acceptance of undertakings in lieu

Non-upfront buyer cases

- 8.24** Where the OFT decision maker concludes that offered undertakings in lieu of a reference are in principle a suitable remedy to the substantial lessening of competition or the identified adverse effects arising from the merger, the OFT issues a public announcement in the form of a press release that the test for reference is met, but that its duty to refer is 'suspended' because it is considering whether to accept undertakings in lieu of reference. This statement will also be made in the version of the OFT's published decision that will be published in redacted form once business secrets have been removed from the confidential version of the decision (see paragraph 6.64 above).
- 8.25** Following announcement of the OFT's decision that its duty to refer the merger is suspended, the OFT may under section 25 of the Act extend its four month statutory timetable for considering a completed merger or under section 97 of the Act the statutory merger notice deadline to allow for the negotiation process. This is to avoid the situation where parties may be deprived of the right to negotiate the actual text of undertakings in lieu because there is insufficient time to do so before the expiry of the relevant statutory deadline.
- 8.26** Once the nature of the OFT's decision has been publicly announced (that is, that the test for reference is met but the parties have offered undertakings in lieu), the Group will prepare a first draft of suitable undertakings in lieu of reference reflecting the offer made by the parties which the OFT is minded to accept. The Group will generally start from a standardised set of undertakings, but will tailor these to the particular factual circumstances of the case. The Group will discuss

the draft set of undertakings with the parties and will agree with them a provisional set of undertakings acceptable both to the OFT and the party or parties providing them.

8.27 The OFT remains under a statutory duty under section 103 of the Act in deciding whether to make a reference to have regard to the need to make a decision as soon as reasonably practicable. It will therefore aim to complete negotiation of the text of the undertakings in lieu with the parties as quickly as possible. In all cases, a reference may still be made if agreement on the details of the undertakings cannot be reached within a reasonable timescale.

8.28 In order to give interested third parties an opportunity to comment, the Act provides under section 90 and Schedule 10 for third parties to be consulted prior to the OFT's final acceptance of any undertakings in lieu. The OFT will publish the draft of the provisionally agreed undertakings and will invite comments from third parties. The OFT is required by the Act to give third parties a period of not less than 15 days in which to respond with comments on the purpose and effect of the proposed undertakings.¹⁰⁸

8.29 To the extent that, as a result of the consultation process or otherwise, the originally published draft undertakings are modified in a material respect, a second consultation period will be required. In such a case, the consultation period for third parties to respond on the modified undertakings is seven days.¹⁰⁹

8.30 Following the necessary consultations, the OFT will ask the parties to sign the final version of the undertakings, after which they will be formally accepted by the OFT (or Secretary of State in the case of public interest cases). The OFT will announce publicly that it has formally accepted undertakings in lieu of reference, thereby ending its duty to refer, and will publish the final version of the accepted undertakings on its website.

Upfront buyer cases

8.31 The procedure described in paragraphs 8.24 to 8.30 above differs in situations where the OFT decides that undertakings in lieu will be

108 Schedule 10 paragraph 2 of the Act specifies a minimum period of 15 days. Subject to an overriding interest in a particularly speedy remedy or other timing constraints in an individual case, the OFT will generally try to give third parties 15 working days in which to respond.

109 Schedule 10 paragraph 2 of the Act specifies a minimum period of seven days. Subject to an overriding interest in a particularly speedy remedy or other timing constraints in an individual case, the OFT will generally try to give third parties seven working days in which to respond.

accepted only where the parties have identified an upfront buyer. Such a decision is made and communicated to the parties at the time that the OFT announces that the duty to refer is suspended because it is seeking undertakings in lieu from the parties.

8.32 In this situation, the OFT will not accept the undertakings in lieu unless a sale agreement, conditional from the buyer's perspective only on acceptance of the undertakings in lieu by the OFT (and the completion of the main transaction if it remains anticipated), has been agreed with a buyer for the divestment business and the OFT considers that the buyer would be acceptable. The OFT will seek an upfront buyer where the risk profile of the remedy requires it, for example where the OFT has reasonable doubts with regard to the ongoing viability of the divestment package and/or there is only a small number of candidate suitable purchasers.

8.33 Where the OFT considers that an upfront buyer is required, the parties will be given a relatively short, individually-determined period following the announcement of the decision suspending the duty to refer in which to identify the upfront buyer, obtain provisional confirmation from the OFT that the buyer is likely to be acceptable, and enter into the sale agreement on the terms described above.¹¹⁰ This time period is likely to be a matter of weeks, rather than months, but will depend on the circumstances.

8.34 In each upfront buyer case, the OFT will, following the announcement of the suspension of the duty to refer, agree with the parties a timetable of milestones for this period in order to ensure that the parties are making timely progress towards the ultimate signing of an agreement with a suitable purchaser. This timetable will be communicated to the parties confidentially and will not be made public. However, failure by the parties to progress a sale as envisaged under the timetable will prompt the OFT to consider whether undertakings in lieu are in fact unworkable such that it should refer the merger to the CC.

8.35 Once the parties have agreed a sale to an upfront buyer, the OFT will publicly consult on the terms of the undertakings in lieu (as discussed in paragraph 8.28 above) and the identity of the proposed purchaser at

¹¹⁰ The OFT requires that the proposed purchaser is in effect contractually bound by the time that the OFT accepts the undertakings in lieu because, once the undertakings in lieu have been accepted, the OFT loses its duty (and ability) to refer the merger to the CC under section 74 of the Act.

the same time. To the extent that the public consultation does not raise material concerns, the OFT will accept the undertakings and formally approve the purchaser.

Procedure following acceptance of undertakings in lieu

8.36 Where no upfront buyer provision was required by the OFT in relation to the undertakings in lieu, the OFT will have a particularly active role to play after it has formally accepted the undertakings from the parties.¹¹¹

8.37 Where the undertakings in lieu are structural in nature, the undertakings, as signed by the parties and accepted by the OFT, will provide for a divestment period within which the merging parties must identify a suitable purchaser for the divestment business and conclude a sale agreement with that buyer.

8.38 Once it has located an appropriate purchaser, the acquiring party will be required to satisfy the OFT that its proposed purchaser is independent of the merged entity, has the resources, expertise, incentive and intention to maintain the business as an on going business, can be expected to receive all regulatory and licensing approvals required, and that making the relevant divestment to the proposed purchaser will not in itself perpetuate or risk creating competition concerns.

8.39 In assessing whether a proposed purchaser should be approved, the OFT will examine information presented by the parties carefully and impartially, but it will only undertake a proportionate amount of investigation and analysis at this phase. If approval of a proposed purchaser requires a detailed investigation, it is likely that the OFT will choose not to approve that purchaser rather than to undertake that in-depth analysis.¹¹²

8.40 Once a purchaser has been formally approved by the OFT, the parties are able to proceed with the divestment. Depending on the terms of the undertakings, the merging parties will be required to achieve signing and/or completion of the divestment transaction by a specific date.

111 Where an upfront buyer was required, then it is expected that the sale will proceed to complete once the undertakings in lieu have been formally accepted.

112 Co-operative Group (CWS) Limited v Office of Fair Trading [2007] CAT 24.

- 8.41** It is important for merging parties and potential divestment purchasers to appreciate that divestments as a result of undertakings in lieu may in themselves result in the creation of a new relevant merger situation (see chapter 3 above). The fact that the OFT has approved a purchaser does not as a formal matter prevent it from investigating any corresponding relevant merger situation. However, in practice, where the divestment purchase raises competition concerns,¹¹³ the OFT will in any event reject the purchaser as being unsuitable by letter to the original merging parties, rather than proceed via full standard merger review of the divestment transaction.
- 8.42** To the extent that merging parties are unable to find a suitable purchaser capable of being approved by the OFT within the time period specified within the undertakings, the undertakings are likely to provide for the OFT to be able to appoint a divestment trustee to sell the divestment business on behalf of the merging parties at no minimum price or for the OFT to direct the parties to sell at no minimum price.
- 8.43** For behavioural undertakings, the OFT has an ongoing monitoring role for the duration of the undertakings under section 92 of the Act.
- 8.44** Whether undertakings are structural or behavioural in nature, if, after accepting the undertakings, it becomes apparent to the OFT that the undertakings are not being or will not be fulfilled, section 75 of the Act gives the OFT order making powers. Such orders are enforced in the High Court.

113 The fact that the acquisition by a proposed purchaser would qualify for investigation pursuant to the share of supply test does not necessarily mean that it would create substantive competition concerns; this will depend on the circumstances of the case and the market(s) in question.

The Secretary of State

- 8.45** In public interest cases, the OFT will advise the Secretary of State whether undertakings in lieu are appropriate pursuant to section 44 of the Act. Any such undertakings in lieu concerning competition issues are negotiated by the OFT and accepted by the Secretary of State. For mergers involving national security considerations, the Ministry of Defence will discuss any proposed public interest undertakings with the parties on the Secretary of State's behalf.

Publication of undertakings and orders

8.46 As required under section 91 of the Act, the OFT will publish the details of all merger undertakings and orders that have been agreed and accepted or imposed under the Act in a Public Register of Undertakings and Orders which can be found on the OFT's website.¹¹⁴ This register covers initial undertakings and orders obtained in completed merger situations for the purpose of preventing pre-emptive action on the part of the parties to the merger, undertakings and orders in lieu of reference to the CC, and final undertakings and orders. The printed version of the register is open to public inspection, by appointment, at the OFT between 10.00 am and 4.00 pm on every day that the OFT is open for business. Publication is designed to ensure that interested third parties are aware of the undertakings. This is important because, in the event of a breach of undertakings, they may take action in the courts under section 94 of the Act.

8.47 Once they are in place, undertakings and orders are monitored by the OFT under section 92 of the Act in order to ensure compliance so that the OFT may advise the CC (or, as the case may be, the Secretary of State) if it considers that any of them should be amended or replaced. Any changes that are agreed are published in the same way as the original undertakings.

114 www.offt.gov.uk/advice_and_resources/resource_base/Mergers_home/register/

9 Public interest mergers

Introduction to public interest case mergers

9.1 The Act provides that – as the default position – the OFT decides whether or not to refer the merger for further investigation by the CC based purely on whether the merger creates the realistic prospect of a substantial lessening of competition. However, the Act also allows for the Secretary of State to assume responsibility for determining whether or not to refer a merger when defined public interest considerations are potentially relevant by issuing a public interest intervention notice (PIIN).

9.2 Section 42 of the Act therefore provides that the Secretary of State may issue a PIIN in the case of mergers that meet the Act's jurisdictional thresholds,¹¹⁵ which have public interest implications and which the OFT has not referred to the CC. At the time of writing, public interest considerations are limited to:

- national security (including public security)
- plurality and other considerations relating to newspapers and other media, and
- the stability of the UK financial system.

9.3 To facilitate this, the OFT has an obligation under section 57 of the Act to inform the Secretary of State where it is investigating a merger that it believes raises material public interest considerations. However, even where a public interest consideration is present, if such a PIIN is not issued, the OFT will treat the case and make its decision on competition grounds as if it were any other merger case (and submissions on the public interest considerations would therefore not be relevant in those circumstances).

9.4 In cases in which the Secretary of State has intervened on media public interest grounds, the Office of Communications (OFCOM) will advise the Secretary of State on the public interest aspects of the case under section 44A of the Act. There is no statutory role for OFCOM unless a PIIN is issued, although the OFT routinely consults regulators about any mergers in which they are likely to have industry-specific knowledge.

¹¹⁵ The Secretary of State may also intervene in certain public interest cases where the jurisdictional thresholds are not met – see paragraph 9.17 below.

Public interest grounds

9.5 Section 58 of the Act details the public interest considerations on which the Secretary of State may intervene in a merger case. These are:¹¹⁶

- national security, including public security
- the need for accurate presentation of news and free expression of opinion in newspapers
- the need for, to the extent that it is reasonable and practicable, a sufficient plurality of views in newspapers in each market for newspapers in the UK or a part of the UK
- the need, in relation to every different audience in the UK or in a particular area or locality of the UK, for there to be a sufficient plurality of persons with control of the media enterprises serving that audience
- the need for the availability throughout the UK of a wide range of broadcasting which (taken as a whole) is both of high quality and calculated to appeal to a wide variety of tastes and interests
- the need for persons carrying on media enterprises, and for those with control of such enterprises, to have a genuine commitment to the attainment in relation to broadcasting of the standards objectives set out in section 319 of the Communications Act 2003, and
- the interest of maintaining the stability of the UK financial system.¹¹⁷

9.6 In addition to those specified considerations discussed above, section 42(3) of the Act also allows the Secretary of State to intervene on the basis of a consideration which is not specified but which the Secretary of State believes ought to be specified. To the extent that the Secretary of State intervenes on the basis of a consideration that he believes ought to be specified, he is required by section 42 of the Act to seek to have that consideration subsequently inserted into section 58 by means of an order approved by both Houses of Parliament.

¹¹⁶ The media considerations were added by the Communications Act 2003. See also BIS (formerly DTI) Guidance: Enterprise Act 2002: Public Interest Intervention in Media Mergers: Guidance on the operation of the public interest merger provisions relating to newspaper and other media mergers, May 2004 and Ofcom guidance for the public interest test for media mergers.

¹¹⁷ Added by the Enterprise Act 2002 (Specification of Additional Section 58 Consideration) Order 2008 SI 2008/2645. The interest of maintaining the stability of the UK financial system is not a relevant consideration for intervention in European mergers or when a merger is referred back to the OFT under Article 4(4) or 9 of the EC Merger Regulation (see below).

Process for public interest cases

9.7 If a PIIN is issued, the case is handled in the following way:

- The OFT will publish an invitation to comment seeking third party views on both competition and public interest issues.
- As well as generally issuing an invitation for comment, the OFT will actively contact other governmental departments, sectoral regulators, industry associations and consumer bodies for their views on public interest issues where appropriate. For example, in a case raising national security issues relating to security of energy supply, the OFT would seek submissions from Ofgem and would pass these on in full to the Secretary of State. In media cases, section 44A of the Act provides expressly for a report by Ofcom.
- The OFT will carry out its review of the jurisdictional and competition issues in the same way as it would for any other case, with the caveat that its timetable will be adapted in order to enable it to provide its report to the Secretary of State by the deadline specified in the PIIN.
- Following its own internal review, the OFT then provides advice to the Secretary of State on jurisdictional and competition issues, which must be accepted (section 46 of the Act). The OFT is also required (other than in media public interest cases) to pass to the Secretary of State a summary of any representations it has received that relate to these public interest matters.¹¹⁸ The Act allows the OFT to provide advice and recommendations on the public interest consideration to the Secretary of State; however, given the OFT's role as a competition agency, it would not normally be expected that the OFT would provide its own advice on public interest issues.
- The OFT will also inform the Secretary of State about the applicability of any of the exceptions to the duty to refer and as to whether it would be appropriate to deal with competition concerns by way of undertakings in lieu. The content of such advice will clearly depend on whether the parties have indicated to the OFT that they would be willing to offer undertakings in lieu of reference.

118 In cases raising media public interest issues, Ofcom will provide a separate report on issues of media plurality and diversity, as occurred in relation to British Sky Broadcasting Group's acquisition of a 17.9 per cent shareholding in ITV plc. In addition, the OFT may also summarise any representations it has received that relate to the media public interest.

- The Secretary of State then makes a judgement on the outcome of the case in the light of the OFT's advice. References to the CC can be made under section 45 of the Act either because the Secretary of State believes that it is or may be the case that the merger has resulted, or may be expected to result, in a substantial lessening of competition and, combined with the relevant public interest consideration(s), operates or may be expected to operate against the public interest; or because, while there is no realistic prospect of a substantial lessening of competition arising from the merger, the public interest considerations are such that it is or may be the case that the merger operates or may be expected to operate against the public interest. Alternatively, the Secretary of State may decide under section 45(6) of the Act not to make a reference on the basis that an anti-competitive outcome in the form of an OFT finding of a realistic prospect of a substantial lessening of competition is justified by one or more public interest considerations. Where the Secretary of State is minded to refer, he will also consider whether undertakings in lieu of a reference are justified.
- If a reference is made on public interest grounds (with or without competition grounds) the Secretary of State will also make the final decision on the merger following the CC's report provided he agrees that the public interest consideration is relevant to the question of the merger.

9.8 If the Secretary of State concludes, after receipt of the OFT's report, that there are no public interest issues that are relevant to the PIIN, the OFT will be instructed under section 56 of the Act to deal with the merger as an ordinary merger case. In any event, any decision in the case based on competition considerations must follow from the OFT's advice on whether or not it is or may be the case that the merger has resulted or may be expected to result in a substantial lessening of competition.

9.9 When the Secretary of State has made a decision as to whether or not to refer the case to the CC, the Secretary of State is required under section 107 of the Act to publish the OFT's report (although the OFT will also wish to make the report available through its website). The parties will be contacted prior to publication to discuss whether

the report contains business secrets that should be excised prior to publication (see paragraph 6.64 above).

- 9.10** A fee is calculated in respect of cases in which a PIIN has been issued in the same way as for normal competition cases (see paragraph 7.3 above).

Public interest intervention in cases under the EC Merger Regulation

- 9.11** The Secretary of State may also intervene on public interest grounds¹¹⁹ in cases falling for consideration under the EC Merger Regulation through the use of Article 21(4) of the EC Merger Regulation (described in paragraph 11.36 below).

- 9.12** Article 21 is invoked by means of the Secretary of State giving the OFT a European Intervention Notice (EIN) under section 67 of the Act. In this situation, the Commission will examine, or continue to examine, the merger on competition grounds in the normal way, but the Secretary of State is able to make a decision on public interest grounds.

- 9.13** The EIN requires that the OFT advise the Secretary of State on the considerations relevant to the making of a reference under section 22 or 33 of the Act which are relevant to the decision on whether to make a reference under the provisions of the Enterprise Act 2002 (Protection of Legitimate Interests) Order 2003.¹²⁰ (These are essentially jurisdictional matters). The OFT is also required to provide a summary of representations received from third parties relating to the public interest considerations.

- 9.14** When a EIN has been issued, the OFT will publish an invitation to comment seeking third party views on the public interest issues (but not on competition issues). The OFT's advice will not contain a competition assessment, as this aspect of the merger remains the responsibility of the Commission. However, the OFT's advice will contain a summary of any representations received from third parties that relate to the public interest considerations specified in the EIN.

119 Article 21(4) of the EC Merger Regulation limits the grounds on which the Secretary of State may intervene. The public interest considerations on which the Secretary of State may intervene are those listed in section 58 of the Act (other than the interest of maintaining the stability of the UK financial system which is expressly stated not to be a consideration for the purposes of intervention under the EC Merger Regulation).

120 SI 2003/1592.

- 9.15** The Secretary of State may make a reference to the CC if he believes that it is or may be the case that, taking account only of the public interest consideration, the creation of the European relevant merger situation operates or may be expected to operate against the public interest.
- 9.16** No merger fee is payable in EIN cases (see chapter 7 above).

Public interest in special merger situations

- 9.17** Section 59 of the Act also allows the Secretary of State to intervene in a very limited number of cases that do not qualify under the Act's general merger regime but where a specified consideration is relevant to the merger. These special merger situations may arise in defence industry mergers if at least one of the enterprises concerned is carried on in the UK by, or under the control of, a body corporate incorporated in the UK and where one or more of the enterprises concerned is a relevant government contractor. In addition, following the Communications Act 2003, a special merger situation may also arise where the merger involves a supplier or suppliers of at least 25 per cent of any description of newspapers or broadcasting in the UK. Unlike the standard jurisdictional test, no increment to this share of supply is required. There will be no competition assessment in such cases.
- 9.18** In cases where the Secretary of State has issued a special public interest intervention notice (SPIIN), the OFT will prepare a report under section 61 of the Act for the Secretary of State advising on whether a special merger situation has been created. The SPIIN will set out the time period within which the OFT must provide this report to the Secretary of State. The OFT will also summarise representations that it has received relating to the considerations in the SPIIN. Given that the OFT is not expert in the considerations that would be expected to be specified in the SPIIN, it is likely to confine itself to summarising and commenting on the representations received by relevant third party experts, such as the Ministry of Defence.

9.19 The Secretary of State may make a reference to the CC under section 62 of the Act if he believes that it is or may be the case that, taking account only of the public interest consideration, the creation of the special merger situation operates or may be expected to operate against the public interest. The OFT's report is published by the Secretary of State at the time the reference decision is announced (and is also made available by the OFT). The parties will be contacted prior to publication to discuss whether the report contains business secrets that should be excised prior to publication (see paragraph 6.64 above).

9.20 No fee is payable in special public interest cases.

10 Interaction with other processes

Mergers of water or sewerage undertakings

- 10.1** In some circumstances, mergers of water or sewerage undertakings in England and Wales are subject to mandatory reference to the CC. Under the Water Industry Act 1991 (as amended by section 70 of the Act) the OFT must refer any merger involving two or more ‘water enterprises’¹²¹ unless the turnover of one or both of them is less than £10 million.
- 10.2** As stated above (see paragraph 4.37), the OFT does not consider the IA process is suitable for advising on whether a structure or transaction triggers the mandatory reference provisions. However, by way of guidance, a hypothetical example of when the OFT believes a mandatory reference to the CC would not be triggered is where an entity that controls a ‘water enterprise’, (A), considers acquiring another ‘water enterprise’, (B), (where the turnover of each of A and B is not less than £10 million) and the parties structure the transaction back-to-back so that either:
- the interest in A is disposed of prior to the acquisition of the interest in B, or
 - there is a mere legal instant in time (*‘scintilla temporis’*) between the acquisition of B and the disposal of A.
- 10.3** In reporting on the effects on the public interest of any merger referred under the Water Industry Act 1991, the CC must have regard to the number of water enterprises under independent control. This is to prevent prejudice to the ability of the Water Services Regulation Authority (OFWAT) to make comparisons between different enterprises in carrying out its regulatory functions.¹²²

Regulated utilities

- 10.4** There are no special provisions under UK merger legislation for regulated utilities such as electricity, gas, telecommunications, rail¹²³ and air traffic services. A merger in these industries, however, may well require the modification of an operating licence or give rise to other issues falling within the ambit of the relevant sectoral regulator. For this reason, the OFT and the regulators work closely together on

¹²¹ A ‘water enterprise’ is an enterprise carried on by a water or sewerage undertaking appointed under section 6 of the Water Industry Act 1991.

¹²² More information about the special water regime can be found in sections 32 to 35 of the Water Industry Act 1991 and the CC guidelines, Water Merger References (CC 9).

¹²³ It should be noted that entering into a rail franchise agreement constitutes an acquisition of control of an enterprise by virtue of section 66(3) of the Railways Act 1993.

such mergers. In some cases, the regulator may issue a consultation document in respect of the merger, the responses to which will inform the views offered to the OFT. The OFT is not bound by the regulator's views but is required to give attention to them.

The City Code

10.5 The procedures under the Act focus on the underlying economic and other substantive effects of a merger. The City Code on Takeovers and Mergers applies to offers for all listed and unlisted public companies (and certain other companies) resident in the UK. The Code operates principally to ensure fair and equal treatment of all shareholders in relation to offers. The OFT is not responsible for its administration or interpretation. Any enquiries should be addressed to:

**The Secretary
The Panel on Takeovers and Mergers
PO Box 226
The Stock Exchange Building
London EC2P 2JX.**

Tel: 020 7382 9026, Fax: 020 7638 1554

Website: www.thetakeoverpanel.org.uk

11 The EC merger regulation

- 11.1** Under the EC Merger Regulation, the Commission has jurisdiction over ‘concentrations with a Community dimension’ (as defined in Articles 1 and 3 of the EC Merger Regulation). National competition authorities (NCAs) may not apply their own competition laws to these mergers, except in certain limited circumstances.
- 11.2** The starting point for the allocation of jurisdiction between the Commission and the OFT is that mergers that fall within the jurisdictional provisions of Article 1 of the EC Merger Regulation are not subject to review under the Act. This is because mergers reviewed by the Commission under the EC Merger Regulation benefit from the ‘one-stop-shop’ principle such that national competition filings are not required in the EU. However, as described further below, the EC Merger Regulation allows for the transfer of cases between NCAs and the Commission in a number of ways. Parties should also be aware that, even in cases where the Commission has and retains jurisdiction, the Commission always consults the NCAs about mergers, and the EC Merger Regulation provides for NCAs to advise the Commission in certain circumstances.¹²⁴
- 11.3** The competent UK authorities for the purpose of the EC Merger Regulation are the Secretary of State for BIS, the OFT and (in certain circumstances) the CC.
- 11.4** The OFT has charge of the UK competent authority role in respect of the majority of mergers falling under the EC Merger Regulation. This means that it is the OFT that liaises with the Commission on the assessment and determination of cases over which the Commission has jurisdiction. Significantly, it also means that the OFT’s functions include deciding whether to request the referral of an EC Merger Regulation case from the Commission to the UK in whole or in part under Article 9 of the EC Merger Regulation and whether to seek to refer a UK merger to the Commission in accordance with Article 22 of the EC Merger Regulation. Alternatively, the OFT may have to determine whether to consent to any request by the parties for the referral of an EC Merger Regulation case from the Commission to the UK in whole or in part under Article 4(4) of the EC Merger Regulation or to a request that a case falling under the Act be transferred to the Commission in accordance with Article 4(5) of the EC Merger Regulation. Each of these mechanisms for the transfer of jurisdiction is discussed in detail below.

¹²⁴ Most notably the Advisory Committee of representatives of the competition authorities of the Member States is required to be consulted prior to the taking of a decision at the end of a detailed investigation.

11.5 The Secretary of State retains responsibility for UK policy on legislative initiatives in relation to the EC Merger Regulation. The Secretary of State also has responsibility for the taking of decisions relating to mergers falling within the EC Merger Regulation on action to protect the UK's national security and other legitimate non-competition interests in accordance with Article 296 EC Treaty or Article 21(4) of the EC Merger Regulation (as described in paragraphs 11.34 to 11.36 below).

Concentrations with a Community dimension¹²⁵

11.6 Mergers that are deemed to be concentrations under the EC Merger Regulation¹²⁶ fall under the jurisdiction of the Commission where they have a Community dimension, that is where they satisfy one of two alternative sets of jurisdictional thresholds:

- either
 - the combined aggregate worldwide turnover of all the undertakings concerned is more than €5 billion, and
 - the aggregate Community wide turnover of each of at least two of those undertakings is more than €250 million
- or
 - the combined aggregate worldwide turnover of all the undertakings concerned is more than €2.5 billion, and
 - in each of at least three Member States, the combined aggregate turnover of all those undertakings is more than €100 million, and
 - in each of at least three of the Member States included for the purposes above, the aggregate turnover of each of at least two of the undertakings concerned is more than €25 million, and
 - the aggregate Community wide turnover of at least two of the undertakings concerned is more than €100 million
- unless
 - in relation to either situation above, each of the undertakings concerned achieves more than two-thirds of its aggregate Community wide turnover within one and the same Member State.

125 See generally the Commission Consolidated Jurisdictional Notice under Council Regulation (EC) No. 139/2004 on the control of concentrations between undertakings OJ 2008 C95/1.

126 According to Article 3(1) and (4) of the EC Merger Regulation, a concentration is deemed to arise where a change of control on a lasting basis results from:

- the merger of two or more previously independent undertakings or parts of undertakings
- the acquisition, by one or more persons already controlling at least one undertaking, or by one or more undertakings, whether by purchase or securities or assets, by contract or by any other means, of direct or indirect control of the whole or parts of one or more other undertakings, or
- the creation of a joint venture performing on a lasting basis all the functions of an autonomous economic entity.

11.7 Those mergers that satisfy one of these two sets of jurisdictional thresholds must be notified to the Commission prior to their implementation, that is, in essence, prior to the merger being completed. There is no specific deadline within which a merger must be notified to the Commission, although notification is formally required following:

- the conclusion of the agreement
- the announcement of a public bid, or
- the acquisition of a controlling interest.

Notification may also be made where the undertakings concerned demonstrate to the Commission a good faith intention to conclude an agreement or, in the case of a public bid, where they have publicly announced an intention to make such a bid, provided that the intended agreement or bid would result in a concentration with a Community dimension.

11.8 The Commission has prescribed the form in which a notification should be made. This is set out in Form CO, published as an annexe to the Commission's Implementing Regulation 802/2004.¹²⁷

11.9 The OFT receives copies of all merger notifications sent to the Commission and it informs the Commission of any competition concerns such mergers may raise for the UK.

11.10 If the Commission decides to open proceedings to initiate a full investigation, OFT staff participate in oral hearings with the merging companies and third parties in Brussels. OFT representatives also attend meetings of the Advisory Committee of representatives of the competition authorities of the Member States, which must be consulted before the Commission can reach a final decision on those cases which have been referred for a full investigation.

11.11 It is helpful if mergers with a Community dimension that might be considered to have a particular impact on competition in the UK are brought directly to the attention of the OFT at the earliest possible stage, in addition to the mandatory notification to the Commission.

¹²⁷ Commission Regulation (EC) No. 802/2004 implementing Council Regulation (EC) No. 139/2004 OJ 2004 L133/1 as amended by Commission Regulation (EC) No. 1033/2008. This can be obtained on the Commission's website: http://ec.europa.eu/competition/mergers/legislation/regulations.html#imp_reg

11.12 The remainder of this chapter considers referrals between the Commission and the OFT. When considering case referrals, the OFT will have regard to the Commission's Notice on case referrals.¹²⁸ In particular, the OFT will take due account of all aspects of the application of the principle of subsidiarity and the importance of legal certainty with regard to jurisdiction. The over-arching principle in case referrals is that jurisdiction should only be re-attributed to another competition authority in circumstances where that authority is the more appropriate for dealing with the case.

¹²⁸ Commission Notice on Case Referral in respect of concentrations, OJ 2005 C56/2 (Commission Notice on Case Referral).

Case referrals from the Commission to the OFT

11.13 In some circumstances, a merger that falls to be considered under the EC Merger Regulation may, in whole or in part, be considered under the Act. There are three relevant provisions of Community law:

- referral of the case at the request of the merging parties prior to notification to the Commission (Article 4(4) of the EC Merger Regulation)
- referral of the case at the request of the OFT following notification to the Commission (Article 9 of the EC Merger Regulation), and
- (whilst not a referral as such) protection of national legitimate interests at the initiative of the Secretary of State (Article 296 EC Treaty and Article 21(4) of the EC Merger Regulation).

Each of these mechanisms is detailed below.

Pre-notification referral to the OFT (Article 4(4) of the EC Merger Regulation)

11.14 Article 4(4) of the EC Merger Regulation allows merging parties to request that the whole or part of a merger that constitutes a concentration satisfying the turnover thresholds in Article 1 of the EC Merger Regulation, and would therefore otherwise be reviewed by the Commission under the EC Merger Regulation, is referred to a Member State (or Member States) that is better placed to review the transaction.

129 Such effects need not be adverse for the purposes of Article 4(4). Recital 16 of the EC Merger Regulation states that the parties are not required to demonstrate that the effects of the concentration would be detrimental to competition.

130 This is published as an annexe to the Commission's Implementing Regulation No. 802/2004 and may be obtained on the Commission's website: http://ec.europa.eu/competition/mergers/legislation/regulations.html#impl_reg

131 Where that Member State takes no such decision within the 15 working days, it is deemed to have agreed to the referral.

11.15 Under Article 4(4) of the EC Merger Regulation, the merging parties may request a referral of the transaction in whole or part to a specific Member State or States before they notify the case to the Commission. In order for the referral to be granted by the Commission, it must be satisfied that the transaction may significantly affect¹²⁹ competition in a market within the named Member State which presents all the characteristics of a distinct market, so that the merger should therefore be examined, in whole or in part, by that Member State. Further guidance on the legal requirements to be satisfied, and the other relevant factors to be taken into account, can be found in the Commission Notice on Case Referral.

11.16 On substance, a transaction suitable for Article 4(4) referral to the UK should affect a market or markets not wider than the UK in scope. The OFT considers that Article 4(4) of the EC Merger Regulation is particularly suited to transactions involving local or regional markets. Additional support for a referral to the UK may include, for example, the following factors:

- the case concerns entirely or largely the UK or a market within the UK
- the OFT and/or the CC have experience in reviewing the market or markets in question
- any possible competition concerns could feasibly be resolved by way of remedies in the UK, in particular where remedies might not be open to the Commission (because the affected market is not a substantial part of the common market), and
- the OFT and/or the CC are already reviewing or about to review another transaction in the same sector, including a competing bid for the target business.

11.17 A request to the Commission under Article 4(4) of the EC Merger Regulation should be made in the form of a Reasoned Submission (Form RS).¹³⁰ Article 4(4) of the EC Merger Regulation stipulates that the Commission shall transmit the Form RS to all Member States without delay and that the Member State mentioned in the Form RS shall, within 15 working days of receiving the submission, express its agreement or disagreement as regards the request to refer the case.¹³¹

The Commission must take a final decision within 25 working days of receiving the Form RS as to whether the conditions for the request are met and whether it is willing to relinquish jurisdiction over the case by referring it in whole or part to the requested Member State. The Commission will thereafter inform the Member States and the requesting party or parties of its decision.¹³²

- 11.18** If an Article 4(4) referral request to the UK has been made, OFT officials make an assessment of the Form RS, checking whether the share of supply and/or turnover tests are met (given that the OFT will have jurisdiction to review the transaction only if the Act's jurisdictional tests are met) and the accuracy and completeness of the information it contains. The OFT will disagree with a referral request if it considers that the Form RS is based on wrong information or assumptions (for example, that the market in question is in fact wider than the UK).
- 11.19** If the OFT does not disagree, and the Commission decides to refer a case to the UK under Article 4(4) of the EC Merger Regulation, national competition law shall apply and the OFT will carry out the procedures previously described in this guidance for the consideration of mergers under the Act. However, Article 4(4) provides certain obligations on the OFT if the case is referred back. These include that the OFT may take only the measures strictly necessary to safeguard or restore effective competition on the market concerned.¹³³
- 11.20** Upon a reference back, the OFT has, under section 34A of the Act, a maximum of 45 working days beginning on the working day after receipt of the Commission's referral decision to inform the merging parties of the result of its preliminary competition assessment,¹³⁴ that is whether it has decided to refer the case to the CC or to seek undertakings in lieu of reference. Although the OFT has a statutory deadline of 45 working days in which to announce its decision, it will generally try to decide the case within its 40 working day administrative timetable (see paragraph 4.65 above).
- 11.21** In circumstances when a merger is referred back to the OFT under Article 4(4) of the EC Merger Regulation, the OFT may require a notification of the merger from the merging parties. Much of this information will already be contained in the Form RS, but additional

132 If the Commission does not take a decision within this period, it is deemed to have adopted a decision to refer the case in accordance with Form RS.

133 Articles 4(4) and 9(8) of the EC Merger Regulation.

134 Pursuant to Articles 4(4) and 9(6) of the EC Merger Regulation. These timing obligations in the EC Merger Regulation do not impact on the CC if the case is referred to it by the OFT.

information may still be needed in order that the notification can be deemed complete such that the OFT can carry out its review. The OFT will generally write to the merging parties as soon as the case has been referred back informing them whether the 45 working day statutory period has commenced or whether the investigation timetable will be immediately suspended until the additional information to constitute a full submission has been received.¹³⁵

¹³⁵ Under sections 34A and 34B of the Act, the 45 working day period is subject to the normal risk of suspension if the parties fail to provide requested information within a specified deadline (see by analogy paragraph 6.3 above). If the notifying parties are unable to provide a satisfactory submission (potentially by way of additional information to the Form RS) on or immediately after receipt of the Commission's decision, the OFT will consider using formal information requests under section 34B of the Act.

¹³⁶ Where only part of the transaction is referred back to the UK, with the remainder being retained for investigation by the Commission, the suspension obligation under Article 7 of the EC Merger Regulation prohibiting parties from implementing the transaction prior to clearance from the Commission will continue to apply.

11.22 In practice, therefore, although the OFT will not start its assessment of the merger until the Commission has decided to agree to the parties' request, parties are recommended to contact the appropriate OFT case officer in advance of the Commission's decision to discuss what further information may be required (in addition to that in the Form RS) to constitute a satisfactory submission for the purposes of the Act in the event of jurisdiction passing to the OFT. Early contact allows for efficient and expedient consideration of cases under the Act upon receipt of a Commission referral decision, and reduces the time between the reference back decision and the formal commencement of the OFT's investigation. Where appropriate, the suitability of undertakings in lieu may also be discussed at this stage.

11.23 In respect of notification options for the parties once a referral request has been accepted, it is in principle open to the parties to use a statutory merger notice (rather than an informal submission) where the transaction remains anticipated. However, although the OFT may ultimately clear the transaction unconditionally, the OFT would caution parties about using a statutory merger notice to notify in this situation (see paragraph 4.55 above). This is particularly because, by definition, transactions that are referred back under Article 4(4) of the EC Merger Regulation may significantly affect competition within the UK. Likewise, the parties should be aware of the risks for the parties in completing the transaction following a referral back but prior to clearance of the transaction by the OFT or CC (see paragraph 4.21 above). Although the parties are free to complete a transaction referred back¹³⁶ to the OFT, the suitability of initial undertakings will be considered by the Mergers Group in the same way as for a purely domestic completed merger upon or shortly after completion (see paragraph 6.29 above).

Post-notification referral to the OFT (Article 9 of the EC Merger Regulation)

11.24 Under Article 9 of the EC Merger Regulation, the OFT may, within 15 working days of receipt from the Commission of a copy of the Form CO notifying the merger, request that the whole or part of a merger be referred to the UK competition authorities for consideration under the Act, if it:¹³⁷

- threatens to affect significantly competition in a market within the UK which presents all the characteristics of a distinct market (Article 9(2)(a)), or
- affects competition in a market within the UK which presents all the characteristics of a distinct market and which does not constitute a substantial part of the common market (Article 9(2)(b)).

137 The effect for the purposes of both Article 9(2)(a) and (b) must be adverse (see paragraphs 35 and 39 of the Commission Notice on Case Referral).

11.25 The Commission must first verify whether the above legal criteria are met. In relation to the first condition, it has discretion to decide whether to refer a case or a part thereof, whereas for the second condition the Commission is required to make the referral if it agrees that the criteria are met. The reference back to the UK may be made in whole or in part, and the Commission may also invite the UK to make a referral request if it considers that the case is suitable for Article 9 application.

11.26 The Commission will inform the OFT and the notifying parties of its decision within 35 working days from notification of Form CO or, where the Commission has already initiated proceedings, within 65 working days.¹³⁸

138 If the Commission does not take a decision within this period following a request, it is deemed to have adopted a decision to refer the case to the UK.

11.27 To assist in considering whether to make an Article 9 request, the OFT may, where it considers it relevant to do so, publish an invitation to comment seeking views from any interested third party on the implications of the merger for competition in the UK and seeking the views of the parties.

11.28 Factors pointing towards the OFT requesting that a case be referred back from the Commission are:

- the case concerns entirely or largely the UK or a market within the UK

- the OFT and/or the CC have experience in reviewing the market or markets in question
- any possible competition concerns could feasibly be resolved by way of remedies in the UK, in particular where remedies might not be open to the Commission (because the affected market is not a substantial part of the common market), and
- the OFT and/or the CC are already reviewing or about to review another transaction in the same sector, including a competing bid for the target business.

11.29 Should such a request be made and granted, the OFT will carry out the procedures previously described in this guidance for the consideration of mergers under the Act. Reflecting the obligations under the EC Merger Regulation,¹³⁹ section 34A of the Act requires that the OFT make its decision on whether or not to refer the merger to the CC, or seek undertakings in lieu or reference, within 45 working days beginning on the working day after the Article 9 referral decision is taken by the Commission.¹⁴⁰ The same principles that apply to notification of the merger following a successful Article 4(4) reference also apply in the case of an Article 9 referral back – see paragraphs 11.21 to 11.23 above.

Relationship between Article 4(4) and Article 9 of the EC Merger Regulation

11.30 Articles 4(4) and 9 of the EC Merger Regulation are both designed to achieve essentially the same goal – namely to transfer jurisdiction, in whole or in part, from the Commission to an NCA where that NCA is better placed to review the competitive impact of the transaction.

11.31 There is no obligation on merging parties to make an Article 4(4) referral request, even where they consider that the requirements for reference back are fulfilled. Nevertheless, the OFT considers that there are certain advantages for parties in using Article 4(4) of the EC Merger Regulation in appropriate cases, rather than waiting for the OFT to make a request under Article 9 of the EC Merger Regulation, namely that:

- although the parties are encouraged to discuss a relevant case up-front with the OFT regardless of whether or not they intend to make an Article 4(4) request, use of the Article 4(4) mechanism typically

¹³⁹ Article 9(6) to 9(8) of the EC Merger Regulation.

¹⁴⁰ This is subject to the usual risk of suspension if parties fail to provide requested information by a specified deadline. If the notifying parties are unable to provide a satisfactory submission on or immediately after receipt of the Commission's decision, the OFT will use its formal information requests under section 34B of the Act in order to suspend the 45 working day time period under section 34A of the Act.

allows for a more open dialogue with the OFT at an early stage in the transaction as to whether the criteria for reference back are satisfied, and

- the parties are guaranteed a decision whether the case will be referred back under Article 4(4) of the EC Merger Regulation within 25 working days of submission of the Form RS, whereas a decision whether or not to refer back under Article 9 of the EC Merger Regulation may be made up to 35 working days after notification of the Form CO (and may be made up to 65 working days after notification if the case is taken into second phase).

11.32 In all cases in which a referral back might be considered appropriate, parties are recommended to contact the appropriate OFT case officer for the sector concerned prior to notification to the Commission to discuss any UK-issues raised by the transaction and, if necessary, what further information may be required by the OFT in the event of a referral back. The suitability of undertakings in lieu may also be discussed.

11.33 In view of the availability of the Article 4(4) referral mechanism, the OFT envisages that the need for the use of Article 9 of the EC Merger Regulation will remain limited. However, use of Article 9 of the EC Merger Regulation may be considered appropriate where there are indications that the merger threatens to affect significantly competition in a market within the UK, the substance of which the OFT may not be able to investigate until after a referral is made. In cases where the OFT considers that it may be better placed to review a transaction, the fact that the parties have chosen not to make an Article 4(4) request will in no way deter the OFT from making a request under Article 9 of the EC Merger Regulation.

Article 296 EC Treaty and Article 21(4) of the EC Merger Regulation

11.34 BIS and appropriate government departments take the lead on liaison between merging parties and the Commission on mergers falling within Article 296 of the EC Treaty or Article 21(4) of the EC Merger Regulation.

11.35 Article 296 of the EC Treaty provides that a Member State is not obliged to supply information the disclosure of which it considers to be contrary to the essential interests of its security, and may take such measures as it considers necessary for protection of those essential interests. This provision has been used in relation to defence mergers.¹⁴¹

¹⁴¹ See Case No. IV/M.1438 British Aerospace / GEC Marconi OJ 1999 C241/8, paragraph 2.

11.36 Article 21(4) of the EC Merger Regulation allows Member States to take appropriate measures to protect legitimate interests, namely public security, plurality of the media, and prudential rules. It does not, however, prevent the Commission from examining the competition implications of such a merger. For further information see the discussion of public interest intervention in cases under the EC Merger Regulation at paragraph 9.12 above.

Case referrals from the OFT to the Commission

11.37 In some circumstances, certain mergers that do not meet the thresholds for notification to the Commission under Article 1 of the EC Merger Regulation may be transferred to the Commission for consideration. There are two relevant provisions of Community law:

- referral of the case at the request of the merging parties (Article 4(5) of the EC Merger Regulation), and
- referral of the case at the request of the OFT (Article 22 of the EC Merger Regulation).

Each of these mechanisms is detailed below.¹⁴²

Pre-notification referral to the Commission (Article 4(5) of the EC Merger Regulation)

11.38 Under Article 4(5) of the EC Merger Regulation, parties to a concentration that does not meet the turnover thresholds for notification to the Commission but is capable of being reviewed under the national merger control laws of at least three Member States may, prior to notification, request that the transaction be examined by the Commission under the 'one stop shop' principle.

¹⁴² See also the Commission Notice on Case Referral and the European Competition Authorities Association (ECA)'s Principles on the Application, by National Competition Authorities within the ECA, of Articles 4(5) and 22 of the EC Merger Regulation (the ECA Principles).

- 11.39** Transactions are deemed 'capable of being reviewed' in the UK if they meet either the share of supply or turnover test under the Act (see chapter 3 above). If parties have any doubts or questions about jurisdictional qualification in this context, they should contact the Mergers Group.
- 11.40** A request to the Commission under Article 4(5) of the EC Merger Regulation should be made in the form of a Form RS.¹⁴³ Further guidance on the legal requirements to be satisfied and other factors to be considered can be found in the Commission's Notice on Case Referral.
- 11.41** Article 4(5) of the EC Merger Regulation stipulates that the Commission shall transmit the Form RS to all Member States without delay and that any Member State competent to examine the merger under its own national competition laws may, within 15 working days of receiving the Form RS, express its disagreement as regards the request to refer the case (thereby vetoing the referral).
- 11.42** The Commission will subsequently inform all Member States and the requesting parties of the outcome. Where at least one Member State having competence to review the merger expresses disagreement, the case shall not be referred. Where no Member State competent to examine the merger expresses disagreement, the transaction is deemed to have a Community dimension and the parties are then required to notify it to the Commission. National merger control laws will no longer apply (including, where relevant, UK jurisdiction under the Act).
- 11.43** When examining Article 4(5) referral requests, the OFT is likely to exercise its veto on referral only where various factors (as discussed in the Commission's Notice on Case Referral) would suggest that the UK is better placed than the Commission to investigate the transaction and carry out enforcement action if necessary.¹⁴⁴ A relevant factor in this regard would be whether the merger appeared likely to have an impact on competition in a market representing a non-substantial part of the common market.

143 This is published as an annexe to the Commission's Implementing Regulation 802/2004 and can be obtained on the Commission's website: http://ec.europa.eu/competition/mergers/legislation/regulations.html#impl_reg

144 For example, the OFT vetoed the referral request in relation to the acquisition by Bayard Capital Partners Pty Ltd of Landis & GYR 15 November 2004 because the main effects of the merger appeared to be felt in the UK in particular in respect of prepayment meters, the UK being the only Member State in which such meters are used.

11.44 Where the merging parties intend to make an Article 4(5) request, but are concerned that there is a risk of the OFT vetoing such a request, they are recommended to contact the appropriate OFT case officer for the sector concerned prior to notification to the Commission to discuss any UK-issues raised by the transaction.

Post-notification referral to the Commission (Article 22 of the EC Merger Regulation)

11.45 Under Article 22 of the EC Merger Regulation, a merger that does not meet the turnover thresholds for notification to the Commission may be referred by a NCA (including by the OFT), singularly or jointly with other NCAs, to the Commission for consideration where it affects trade between Member States and threatens to significantly affect competition within the territory of the Member State or States making the request.

11.46 When a merger is notified to the OFT, or otherwise comes to its attention, the OFT will try to determine as quickly as possible whether the merger is appropriate for referral to the Commission under Article 22 of the EC Merger Regulation. Although there is no restriction under Article 22 of the EC Merger Regulation that Member States may make a request only when they would be competent to review the transaction under their own national competition laws, the OFT would be unlikely, absent unusual circumstances, to make such a request under Article 22 of the EC Merger Regulation unless the merger would qualify for investigation under the Act.¹⁴⁵

11.47 When considering whether to make a referral request under Article 22 of the EC Merger Regulation, the OFT will therefore examine whether the merger satisfies the following criteria:

- it is a concentration
- that affects trade between Member States, and
- that threatens to significantly affect competition within the UK.

11.48 The OFT will also take into account other considerations in trying to establish whether a merger might be appropriate for an Article 22 referral request, including any third party feedback and whether:

- a relevant geographic market affected by the concentration is wider than national

¹⁴⁵ It is likely that any horizontal merger that meets the test under Article 22 of the EC Merger Regulation of threatening to significantly affect competition within the UK would qualify for investigation under the share of supply test under the Act.

- the concentration is subject to filing in several EU Member States such that parties would benefit from the 'one-stop-shop' review by the Commission (although this fact by itself does not make a case an automatic candidate for referral to the Commission)¹⁴⁶
- suitable remedies for any competition concerns identified would lie outside the OFT's jurisdiction, and
- whether the transaction has already been reviewed by one or more Member States and, if so, whether a further review by the Commission would be useful and proportionate.

146 Guidance on the circumstances in which NCAs are likely to use Article 22 is contained in the Commission's Notice on Case Referral and the ECA Principles.

11.49 The OFT will carefully consider whether the Commission appears the best-placed authority to consider the merger in terms of gathering relevant information and, if necessary, securing appropriate remedies. This is more likely when the assets concerned by the transaction are located outside the UK when, for example, it would be difficult for UK authorities to obtain a remedy in the event that the merger is found to raise competition concerns.

147 Footnote 43, Commission's Notice on Case Referral.

11.50 Article 22 of the EC Merger Regulation provides that Member States have 15 working days to make a request for referral from the date on which the transaction is notified or, if no notification is required, otherwise 'made known' to the relevant NCA. Commission guidance stipulates that the notion of 'made known' should be interpreted as implying sufficient information to make a preliminary assessment as to the existence of the criteria for the making of a referral request pursuant to Article 22.¹⁴⁷ As the UK has a voluntary system of notification, the OFT therefore equates 'made known' for the purposes of the 15 working day time period with the date on which the OFT accepts that the cumulative information supplied by the parties constitutes a satisfactory submission under the Act, which will typically include in this context the provision of market shares at an EEA level where this is appropriate (see paragraph 5.9 above).¹⁴⁸

148 The OFT believes that any other interpretation as to when the Article 22 timetable commences would place the UK at odds with the timetable for the application of Article 22 in all other Member States (which have compulsory notification regimes) and would in practice potentially deprive Article 22 of substantial effect in respect of the UK, thereby fragmenting the coherence of the case allocation regime under the EC Merger Regulation. This does not, however, prevent the OFT from making an Article 22 request before it has received a satisfactory submission.

11.51 Article 22 of the EC Merger Regulation stipulates that the Commission must inform Member States without delay of the receipt of the initial request. Other Member States that have not yet requested a referral have the right to join the initial request within 15 working days of being informed of the initial request. All national time limits, including

the OFT's administrative and statutory timetables under the Act, are suspended during this period.

- 11.52** The OFT will conduct a less detailed investigation for the purposes of joining a request than when it initiates itself an Article 22 request, reflecting the lower standard required for joining a request than making one. In determining whether to join an existing request, it will take into account views of the parties and whether the parties would benefit from the 'one-stop-shop' review by the Commission. It will have particular regard to whether the relevant geographic market affected by the concentration is wider than national. To the extent that the relevant geographic market was UK-wide, or narrower, the OFT would be significantly less likely to join a request than if the market in question were wider than national.
- 11.53** The Commission has 25 working days after all the Member States have received the initial request from the Commission to make its decision on referral. If the Commission agrees to examine the transaction in accordance with a request by the OFT, national legislation under the Act no longer applies and the Commission will request a notification under the EC Merger Regulation from the parties. If the OFT decides not to initiate or join a request under Article 22, the provisions of the Act will continue to apply, although any administrative timetable may be affected. However, the OFT will continue to cooperate with any parallel consideration of the merger by other NCAs and/or the Commission.
- 11.54** In the interests of good administrative practice, the OFT will inform the notifying parties as soon as possible that a referral of the merger is being considered and, where possible, invite them to provide their views in writing or at a meeting. While the parties may inform the OFT that they would be in favour of an Article 22 reference, the agreement of the parties is not considered a necessary condition for a referral. If the OFT decides to request a referral, it will inform the parties using the normal warning system one hour in advance of public announcement under the Act (see paragraph 6.64 above). In those cases where a press release is issued, this will be sent to the parties at the same time.

11.55 The OFT will also informally contact the Commission as soon as possible upon consideration of an Article 22 referral of a merger in order to verify its position regarding the option. The consent of the Commission is actively sought.¹⁴⁹ A waiver is sought from the parties to enable the copying of any documents regarding the merger received in the context of proceedings under the Act to the Commission and it is recommended that the notifying parties prepare a confidentiality waiver in advance if they believe that an Article 22 request might be considered by the OFT.¹⁵⁰

149 The Commission may also inform the OFT that it considers a transaction fulfils the criteria for a referral and invite it to make a referral request.

150 Examples can be found at: www.internationalcompetitionnetwork.org/media/archive/0611/NPWaiversFinal.pdf

Annexe A

The statutory merger notice

151 Described in the Enterprise Act 2002 (Merger Prenotification) Regulations 2003 SI 2003/1369 and previously referred to as the 'statutory voluntary pre-notification' procedure.

- A.1** The statutory merger notice procedure¹⁵¹ makes provision for a proposed public merger to be considered within 20 working days, with a maximum extension of 10 working days. Subject to some exceptions, the merger would be automatically cleared where no reference had been made by the end of that period.
- A.2** Under this procedure, a company must use the prescribed merger notice form to set out the basic information that the OFT will require about the transaction, with details of the markets involved. Copies of the form, with further guidance on current procedures, can be obtained from the OFT at the address shown at the end of this guidance or as a downloadable document from the OFT website.

Submission of a merger notice

- A.3** A merger notice may be given only by an 'authorised person', defined as any person carrying on an enterprise to which the notified arrangements relate. The authorised person may, however, appoint a representative – such as a firm of solicitors – to complete the notice on his behalf and to act for him in further correspondence with the OFT.
- A.4** The completed notice may be delivered to the OFT by post, by hand, by fax or by email, together with the appropriate fee made payable to the OFT. If the appropriate fee is transmitted to the OFT via the BACS system information relating to this transfer must be forwarded to the Group so that the payment can be matched with the appropriate submission.

Timing

- A.5** The notification period begins on the first working day after receipt of the notice – with the requisite fee. (Working days exclude Saturdays, Sundays and days which are bank holidays in England and Wales.) Any notice received after 5.00pm or on any day which is not a working day is treated as having been received on the next working day. The period for considering the notice will begin on the working day following that. The consideration period expires 20 working days later (or on the last working day of any extension period). The OFT writes to the 'notifier' (the authorised person or the appointed representative who submits

the notice) to confirm receipt of the notice and the date on which the consideration period expires.

- A.6** If the OFT decides to extend the consideration period, it will inform the notifier before the original consideration period expires – usually in writing. In some urgent cases notice may be given by phone, with subsequent confirmation in writing.
- A.7** As well as the standard 10 working day extension the OFT may extend the total period of consideration by an additional 10 working days if the Secretary of State has issued an intervention notice in respect of the case. The OFT may also extend the period for considering a merger notice if the Commission is considering a request, in relation to the matter concerned, under Article 22(1) of the EC Merger Regulation, or if undertakings in lieu of a reference are being negotiated.
- A.8** Companies that intend to notify mergers subject to the City Code on Takeovers and Mergers should bear in mind the need to reconcile submission of the notice with the requirements of the Code. If they are seeking a decision by the first closing date of an offer, they will need to submit the notice to the OFT well before the posting of the offer document. The OFT cannot be bound by the offer timetable however, and has the discretion to extend the consideration period if necessary.

Rejection of a merger notice

- A.9** The OFT can reject a merger notice for five reasons:
- it suspects the information given in the notice, or subsequently, to be false or misleading
 - it suspects that the parties do not propose to carry the notified arrangements into effect
 - the parties fail to provide on time, or at all, the information specified in the notice, or any supplementary information requested by the OFT
 - the notified arrangements appear to be a concentration with a Community dimension within the EC Merger Regulation, or
 - the requisite fee is not paid at the time of submitting the merger notice.

A.10 The OFT can reject a notice at any time during the consideration period. The decision takes effect from the moment it is sent to the notifier or an authorised representative. The OFT will give notice in writing (including by fax or other form of electronic transmission), although advance notice is normally given by phone.

Request for further information

A.11 On receipt of the notice, the OFT may decide that it needs further information in order to analyse the effects of the merger. It will normally issue a request for information by notice under section 99(2) of the Act and will specify the time by which the information must be provided. If the information is not supplied by that time, the OFT may reject or extend the notice. Alternatively, in urgent cases the OFT may request information informally by phone.

A.12 Any information supplied in response to a written request must be given in writing. Information delivered after 5.00pm, or on any day which is not a working day, will be deemed to have been received on the next working day.

Withdrawal of a merger notice

A.13 A company can withdraw a notice at any time. The withdrawal must be made in writing by the notifier or an authorised representative, and may be delivered by hand, post, fax, or email. The merger fee cannot, however, be refunded unless the merger is caught by the EC Merger Regulation, the merger is found not to qualify, or the merger is referred to the Commission under Article 22(3) of the EC Merger Regulation.

A.14 Where a merger notice is withdrawn, but the OFT suspects that the parties nevertheless propose to carry the notified arrangements into effect, it will continue to examine the merger as if the merger had been notified by way of informal submission. Where a merger fee had already been paid at the time of submission of the merger notice, no further fee will be payable upon the OFT announcing its decision whether or not to refer the merger to the CC.

Exceptions to automatic clearance

A.15 There are some limited circumstances in which a notified merger can still be referred to the CC after expiry of the consideration period (whether extended or not). These are where:

- the notice is rejected by the OFT
- the notice is withdrawn
- the proposed merger is completed before expiry of the consideration period
- before the merger covered by the notice is completed – any of the enterprises concerned enters into an unrelated merger with any other enterprise not covered by the notice
- the merger covered by the notice is not completed within six months of the expiry of the consideration period
- any information supplied by the notifier (or any associate or subsidiary) is in any material respect false or misleading
- any material information which is, or ought to be, known to the notifier (or an associate or subsidiary) is not disclosed at least five working days before the end of the consideration period (such information must be given in writing), or
- the OFT (or the Secretary of State in public interest cases) has given notice that it is seeking undertakings in lieu of reference and has not been notified by the relevant person that it is not willing to give such undertakings. If the person concerned does give such a notice, the OFT (or Secretary of State as appropriate) then has 10 working days within which to make a reference.

Annexe B

Guidance on the calculation of turnover for the purposes of Part 3 of the Enterprise Act 2002

- B.1** This Annexe provides guidance on the calculation of turnover for the purposes of Chapter 1 of Part 3 of the Act.
- B.2** While this Annexe is intended to help explain the detailed provisions of the law concerning turnover calculation, it should not be regarded as a substitute for the Act and secondary legislation made under it. Nor should it be regarded as a substitute for expert legal advice on the interpretation of the Act and secondary legislation.

Background

B.3 Under the turnover test in the Act, a relevant merger situation will arise if two or more enterprises cease to be distinct and the turnover in the United Kingdom of the enterprise being taken over exceeds £70 million.¹⁵² The definition of a relevant merger situation is explained in more detail in chapter 3.

¹⁵² Section 23(1)(b) of the Act.

B.4 The turnover of the enterprise being taken over is, for these purposes, calculated by taking together the total value of the UK turnover of all the enterprises ceasing to be distinct and deducting either:

- (i) the UK turnover of any enterprise which continues to be carried on under the same ownership and control, or
- (ii) if no enterprise continues to be carried on under the same ownership or control, the UK turnover of the enterprise whose turnover has the highest value.¹⁵³

¹⁵³ Section 28(1) of the Act.

B.5 In most relevant merger situations, this means in practice that the applicable turnover for mergers within (i) above – which is most takeovers and acquisitions – will be the UK turnover of the target enterprise. For mergers falling within (ii) above – a full legal merger or a joint venture combining all of the parties' assets and businesses, for example – the applicable UK turnover will be that of the enterprise having the lower turnover (or, put another way, in this scenario both enterprises must have UK turnover exceeding £70 million).

B.6 The method of calculating the applicable turnover is set in the Enterprise Act 2002 (Merger Fees and Determination of Turnover) Order 2003 (the Order).¹⁵⁴

¹⁵⁴ SI 2003/1370.

Period over which turnover is calculated

- B.7** The relevant period used for the purposes of determining turnover under Part 3 of the Act is the business year preceding either: the date the enterprises ceased to be distinct, in the case of a completed merger; or the date of the OFT's decision whether or not to make a reference, in the case of a proposed merger. However, in either case, the OFT may substitute such earlier date as it considers appropriate.¹⁵⁵ In practice, the OFT will usually consider the turnover for the last completed 'business year' preceding the date the enterprises ceased to be distinct (for a completed merger) or the date of notification (in the case of a proposed merger).
- 155 Article 11(2)(a) and (b) of the Order.
- B.8** A 'business year' for these purposes is any period of more than six months for which accounts have been or will be prepared.¹⁵⁶ In general, this will, of course, be a 12-month period. Where (perhaps because the enterprise has been newly formed) there is a period for which there is no preceding business year then the applicable turnover is the turnover for that shorter period.¹⁵⁷
- 156 Article 2(c) of the Order.
- 157 Article 11(4) of the Order.
- B.9** If the preceding business year is not a period of 12 months, then turnover, for the purposes of Chapter 1 of Part 3 of the Act, is arrived at by adjusting the applicable turnover received in that period by the same proportion as 12 months bears to that period.¹⁵⁸ Thus, if the preceding business year for an enterprise ceasing to be distinct is a 9 month period during which the applicable turnover was £54 million, then turnover for this purpose (ie for determining whether the jurisdictional threshold is met) would be £72 million ($£54 \text{ million} \div 9 \times 12$).
- 158 Article 2(b) of the Order.
- B.10** In determining the applicable turnover of an enterprise the OFT may take into account events which have occurred since the end of the business year and which may have a significant impact on the turnover of the enterprise ceasing to be distinct.¹⁵⁹ This allows the OFT to take account of acquisitions or divestments or other transactions which have had or will potentially have a continuing positive or negative effect on the turnover of the enterprise. The OFT would only expect to exercise this discretion in cases where the effect may impact upon the question of jurisdiction or the fee due.
- 159 Article 11(3) of the Order.

Applicable turnover

B.11 The applicable turnover of an enterprise is the turnover of the enterprise arising during the previous business year. It comprises the amounts derived from the sale of products and the provision of services which it makes in the ordinary course of its business activities to customers (businesses or consumers) in the UK, net of any sales rebate, value added tax and other taxes directly related to that turnover.¹⁶⁰ The calculation of turnover for these purposes should be interpreted in accordance with accounting principles and practices that are generally accepted in the UK.¹⁶¹ Turnover includes any aid granted by a public body to a business which is directly linked to the sale of products or the provision of services by the business and therefore reflected in the price of those products/services.¹⁶² Special provisions, described below, apply to an enterprise which is (in whole or in part) a credit institution, financial institution or insurance undertaking.

160 Paragraph 3 of the Schedule to the Order.

161 Paragraph 2 of the Schedule to the Order.

162 Paragraph 13 of the Schedule to the Order.

Credit institutions and financial institutions

B.12 The applicable turnover of an enterprise which, in whole or in part, is a credit institution or financial institution is the sum of certain specified income received by the branch or division of that institution in the UK, after the deduction of value added tax and other taxes directly related to those items.¹⁶³ The types of income specified for these purposes are:

- (i) interest income and similar income
- (ii) income from securities:
 - income from shares and other variable yield securities
 - income from participating interests
 - income from shares in affiliated undertakings
- (iii) commissions receivable
- (iv) net profit on financial operations
- (v) other operating income.

These types of income will be given the same meanings as they are given in Council Directive (EEC) 86/635.¹⁶⁴

163 Paragraphs 10 and 11 of the Schedule to the Order.

164 OJ 1986 L372/1.

Insurance undertakings

B.13 The applicable turnover of an enterprise which, in whole or in part, is an insurance undertaking is the value of the gross premiums received from residents of the UK after deduction of taxes and certain other premium-related deductions.¹⁶⁵ Gross premiums received comprises all amounts received together with all amounts receivable in respect of insurance contracts issued by or on behalf of an insurance undertaking, including outgoing reinsurance premiums.

165 Paragraphs 10 and 12 of the Schedule to the Order.

Enterprises treated as under common ownership or control

B.14 Where an enterprise ceasing to be distinct consists of two or more enterprises which are under common ownership or common control the applicable turnover is calculated by adding together the applicable turnover of each of those enterprises.¹⁶⁶ For the purposes of determining whether enterprises are treated as being under common control when calculating the applicable turnover, the provisions of section 26(2) and (3) (as reproduced in paragraphs 5 and 6 of the Schedule to the Order) and section 127 of the Act apply as they apply in the Act for the purposes of determining whether enterprises have ceased to be distinct.¹⁶⁷

166 Paragraph 4 of the Schedule to the Order.

167 Paragraphs 5, 6 and 7 of the Schedule to the Order.

B.15 As a result, applicable turnover may include not only the applicable turnover of the particular enterprise ceasing to be distinct but also that of certain other enterprises to which it is 'linked'. In particular, this might include the applicable turnover of any enterprise over which the enterprise ceasing to be distinct has control for the purposes of section 26(3) (as reproduced at paragraph 6 of the Schedule) of the Act – that is where the interest held confers, at least, the ability materially to influence policy. Where applicable turnover includes the applicable turnover of a linked enterprise, in which the enterprise ceasing to be distinct has less than a controlling interest, the whole of the applicable turnover of the linked enterprise is included in assessing whether the jurisdictional test is met. (There is no reduction simply because the interest is less than a controlling interest.)

B.16 For example:

- (i) Company A acquires Company B and also its subsidiaries B1 and B2: B and B1 and B2 are enterprises of interconnected bodies corporate which are treated as being under common control and their turnover is taken together in arriving at the applicable turnover of the enterprises ceasing to be distinct.
- (ii) Company A acquires Company C which also has a significant shareholding – conferring at least material influence – in Company D. The turnover of Company C and Company D is taken together in determining the applicable turnover.
- (iii) Partnerships A, B and C act together to secure control of Partnership D and form Partnership E. Partnerships A, B and C are associated persons and their turnover is added together. To determine the applicable turnover, the higher of the two turnover figures (that is, of A, B and C together or of D) is deducted from the combined turnover figure (of A, B, C and D).

B.17 In the case of some joint ventures, none of the enterprises will remain under the same ownership or control. For example, Company A and Company B may form a 50:50 joint venture (Newco) incorporating all their assets and businesses. In this case, neither enterprise A or B will remain under the same ownership or control as previously. In determining the relevant applicable turnover, the highest turnover (of A or B) would therefore, effectively, be ignored. By contrast, where Company A and Company B form a joint venture incorporating their assets and businesses in a particular area of activity, each parent with control ceases to be distinct from the target business contributed to the joint venture by the other parent, but the parent companies themselves remain under the same ownership and control after the merger. Therefore, the parent companies have their turnover deducted and the relevant turnover is the sum of the turnover of each of the contributed enterprises.

Treatment of intra-group transactions

B.18 To avoid double counting, applicable turnover does not include amounts that are derived from transactions involving the sale of goods or provision of services between enterprises that are and will remain, post-merger, under the same common ownership or common control.¹⁶⁸ In other words, external sales only are taken into account.

¹⁶⁸ Paragraph 8 of the Schedule to the Order.

- B.19** However, in certain cases the OFT may take into account sales that were previously internal to a group and may attribute an appropriate value to such sales. This is to allow the OFT to make a sensible assessment of the turnover for jurisdictional purposes of the business being sold.
- B.20** Where, as a result of the merger, one or more enterprises will cease to be under the same common ownership or common control – that is, where what was an intra-group transaction pre-merger would, post-merger, be regarded as an external transaction – then the OFT may treat the amounts derived from the previously internal transactions as applicable turnover. In these cases, if such transactions have not resulted in any turnover, or the OFT believes that the turnover attributed to them does not reflect open market value, then the OFT may attribute an appropriate value to those transactions for inclusion in the applicable turnover.¹⁶⁹
- B.21** For example, the enterprise ceasing to be distinct may be part of a vertically integrated process, a mill supplying flour to a downstream baking operation say. It is possible that, pre-merger, the raw material (flour) may be supplied by the mill to the baking operation at a nil value or less than market price. If only the mill was being taken over, the turnover attributed to the milling operation may, as a result, be artificially low. In these circumstances the OFT might exercise its discretion to take into account the pre-merger supplies of raw materials (flour) to the baking operation in calculating the applicable turnover, and to attribute a more appropriate value for those supplies. In seeking to re-value the turnover attributed to the supply of such goods so that it more accurately reflects an open market value, the OFT might have regard to the terms of any future supply agreement that might be part of the transaction as well as market prices more generally. Again, it is likely that the OFT would only seek to exercise this discretion in those cases where the effect may impact upon the question of jurisdiction or the fee due.

169 Paragraph 9 of the Schedule to the Order.

Treatment of foreign currencies

- B.22** The turnover test is expressed in terms of pounds sterling. If it is necessary to convert foreign currencies in order to arrive at this figure then the OFT would usually be content to accept the approved exchange rate applicable at the date of the accounts.

Contact addresses

For further information about the application of competition law to mergers in the UK, and to obtain copies of the statutory merger notice form, contact:

**The Mergers Group
Office of Fair Trading
Fleetbank House
2-6 Salisbury Square
London EC4Y 8JX**

**Tel: 020 7211 8917/8452/8586
Fax: 020 7211 8916
OFT switchboard: 020 7211 8000
OFT website: www.offt.gov.uk**

For further information about public interest mergers, contact:

**Consumer and Competition Policy Directorate
Department for Business, Innovation and Skills
1-19 Victoria Street
London SW1H 0ET**

**BIS switchboard: 020 7215 5000
BIS website: www.bis.gov.uk**

For further information about the EC Merger Regulation, contact:

**Commission of the European Communities
Directorate-General for Competition
Merger Registry
Rue Joseph II / Jozef II Straat 70
1000 Brussels
Belgium**

**Tel: (+32) 2 296 5040
Fax: (+32) 2 296 4301
Commission switchboard: (+32) 2 299 1111
Commission's website:
http://ec.europa.eu/comm/competition/index_en.html**

